

CENTER FOR

ASTROPHYSICS

HARVARD & SMITHSONIAN



The Chandra Source Catalog 2.0

F. Civano (CfA/CXC)

On behalf of the *Chandra* Source Catalog team

Christopher Allen¹, Craig S. Anderson¹, Jamie A. Budynkiewicz¹, Douglas Burke¹, Judy C. Chen¹, Francesca Civano¹, Raffaele D'Abrusco¹, Stephen M. Doe², I. Evans, Janet D. Evans¹, Giuseppina Fabbiano¹, Daniel G. Gibbs II¹, Kenny J. Glotfelty¹, Dale E. Graessle¹, John D. Grier¹, Roger M. Hain¹, Diane M. Hall³, Peter N. Harbo¹, John C. Houck¹, Jennifer Lauer¹, Omar Laurino¹, Nicholas Lee¹, J. Rafael Martinez-Galarza¹, Michael L. McCollough¹, Jonathan C. McDowell¹, Warren McLaughlin¹, Joseph B. Miller¹, Douglas L. Morgan¹, Amy E. Mossman¹, Dan T. Nguyen¹, Joy S. Nichols¹, Michael A. Nowak⁴, Charles Paxson¹, David A. Plummer¹, Francis A. Primini¹, Arnold H. Rots¹, Aneta Siemiginowska¹, Beth A. Sundheim¹, Michael S. Tibbetts¹, David W. Van Stone¹, and Panagoula Zografou¹

¹Smithsonian Astrophysical Observatory

³Northrop Grumman Mission Systems

²Formerly Smithsonian Astrophysical Observatory

⁴MIT Kavli Institute for Astrophysics and Space Research

100 1000
ons per stack

1 2 5 :
Observations p

CSC 2.0 and CSC 1.0

	CSC 1	CSC 2
Individual obsids	5110	10,382
Obsid years	1999-2009	1999-2014
Total exposure		245.8 Ms
longest exposure	190 ks	5.8 Ms
Counts on-axis	~10	~4-5
Number of sources	106,586	317,167
Number of detections	158,071	928,280

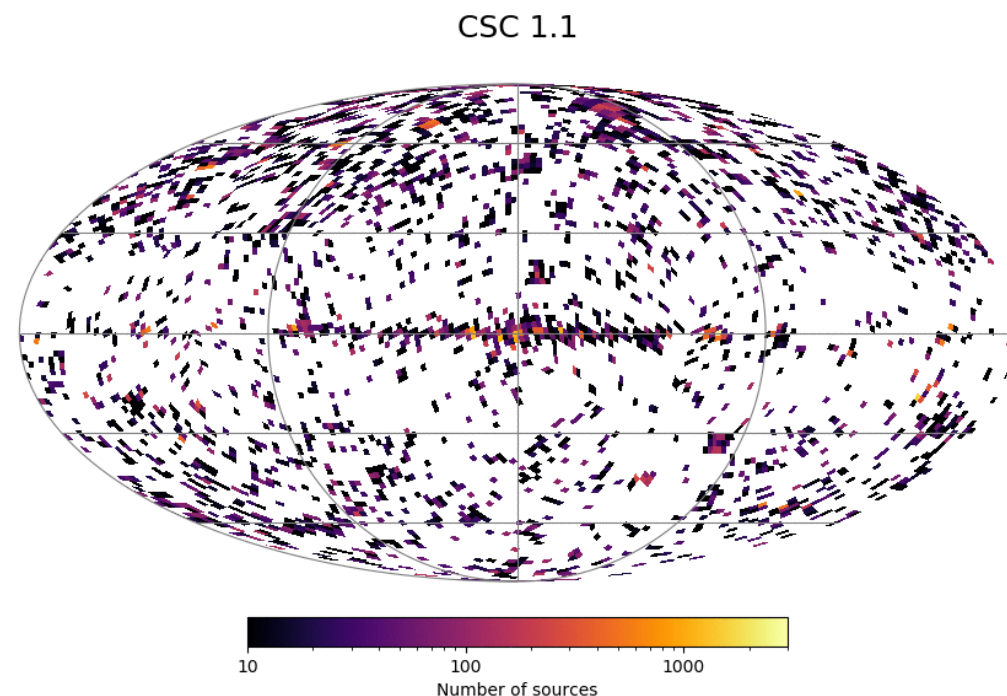

~550 deg²
Area covered
~1.3% of sky

Comparison with other catalogs

Total Observation Detections

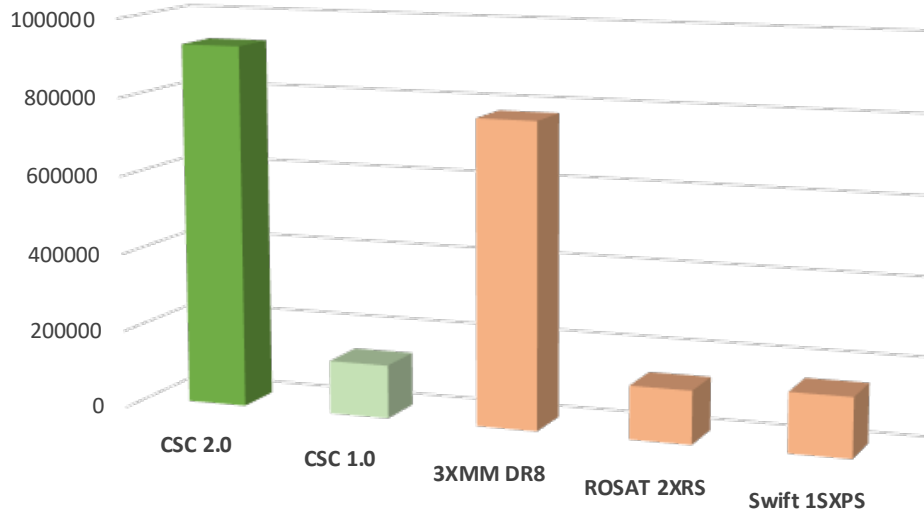

Peak Source Density in 10' Diameter

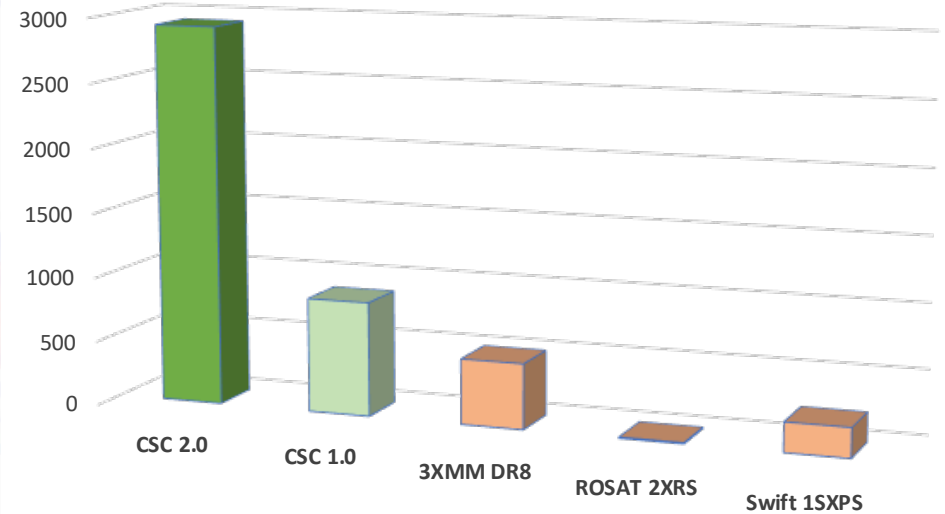

Average Source Density

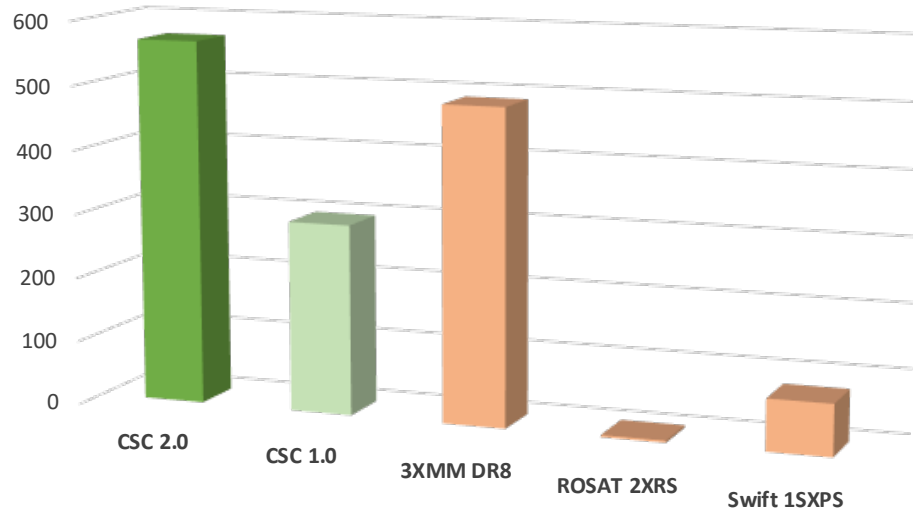

CSC 2.0 as a survey

CHAND
SOURCE CAT

More sensitive

~550 deg²
Area covered

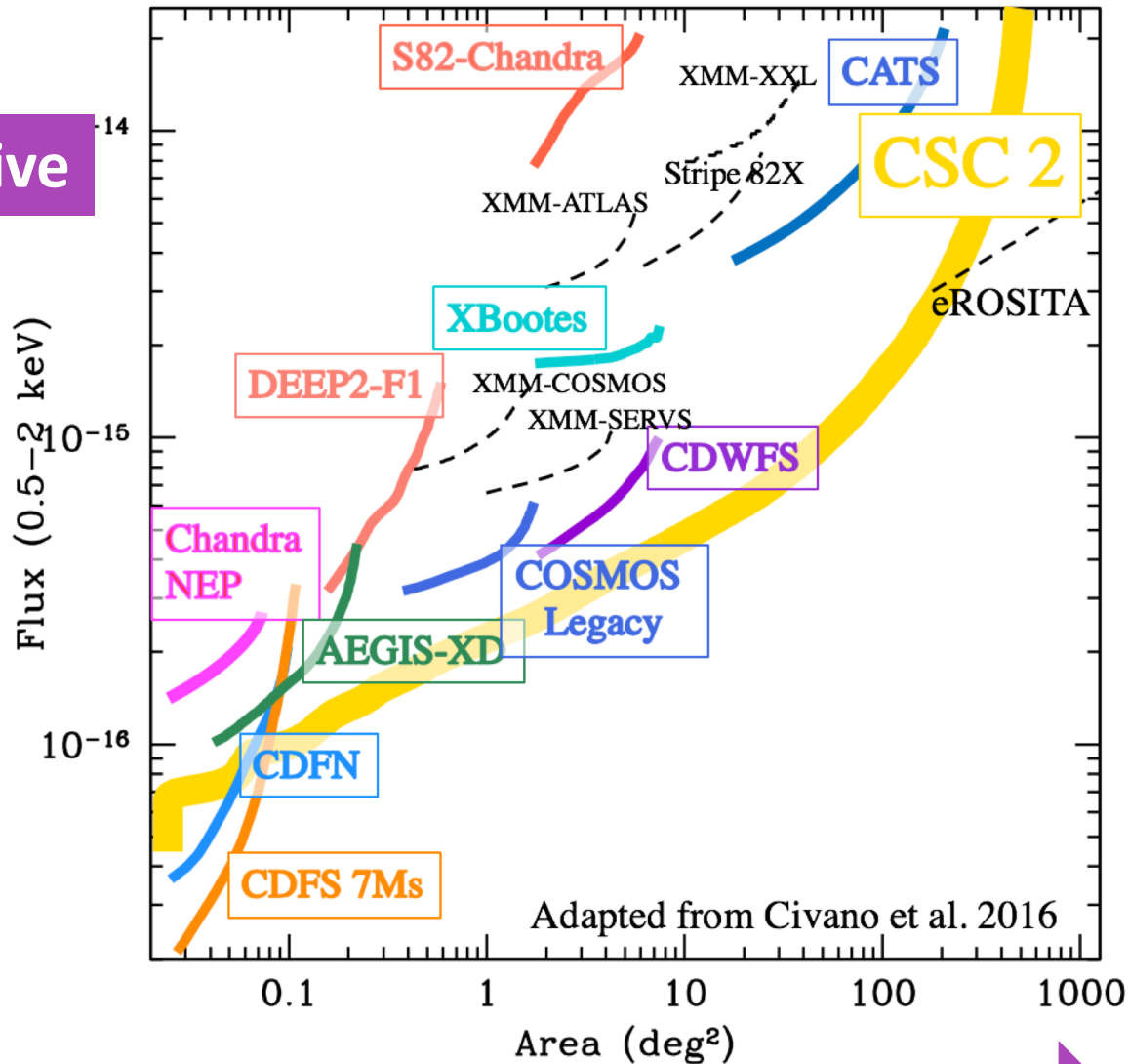

LARGER AREA

F. Civano – CIAO workshop – AAS 2020

100 1000
ons per stack

1 2 5 :
Observations p

CSC 2.0 features



- **Source detection on stacked observations**

New source detection approach

- Wavelet detection with “permissive” parameters *plus* entirely new Voronoi tessellation algorithm for both background determination *and* source detection
- Maximum likelihood estimator grades candidate detection and improves on-axis detection limit ~ 5 net counts for exposures < 15 ks
- MCMC draws provide relative astrometry position error *ellipses*
- Aperture photometry PDFs computed using Bayesian algorithms
- Multiple observations grouped by multi-band Bayesian Blocks algorithm to improve S/N even for variable sources (properties archived for each block)
- Integrated multi-band limiting sensitivity computed on $4'' \times 4''$ pixels

● 100
● 1000
dots per stack

1 2 5 :
Observations p

Stacked observations

STACKS: sum of observations with pointings within 1' to increase sensitivity

FOVs of 3 observations

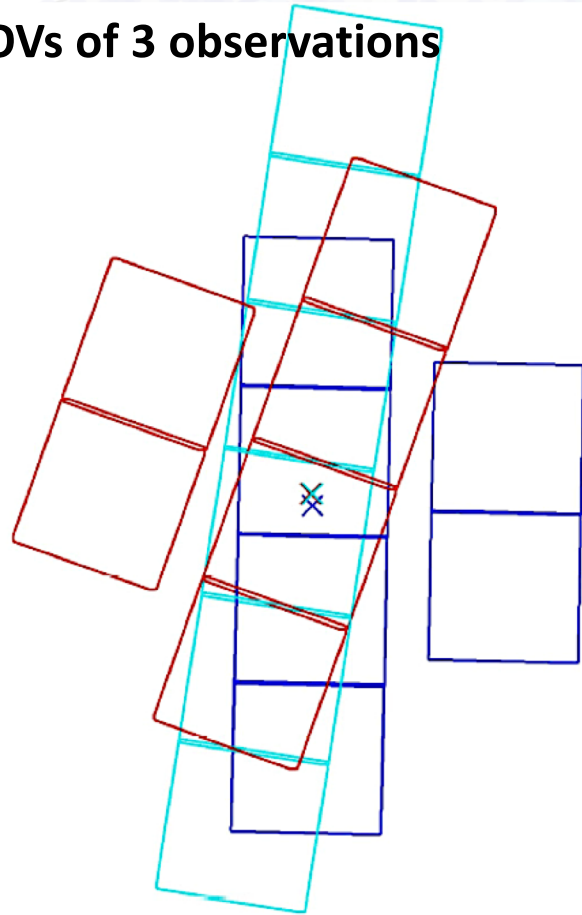

Stack outline

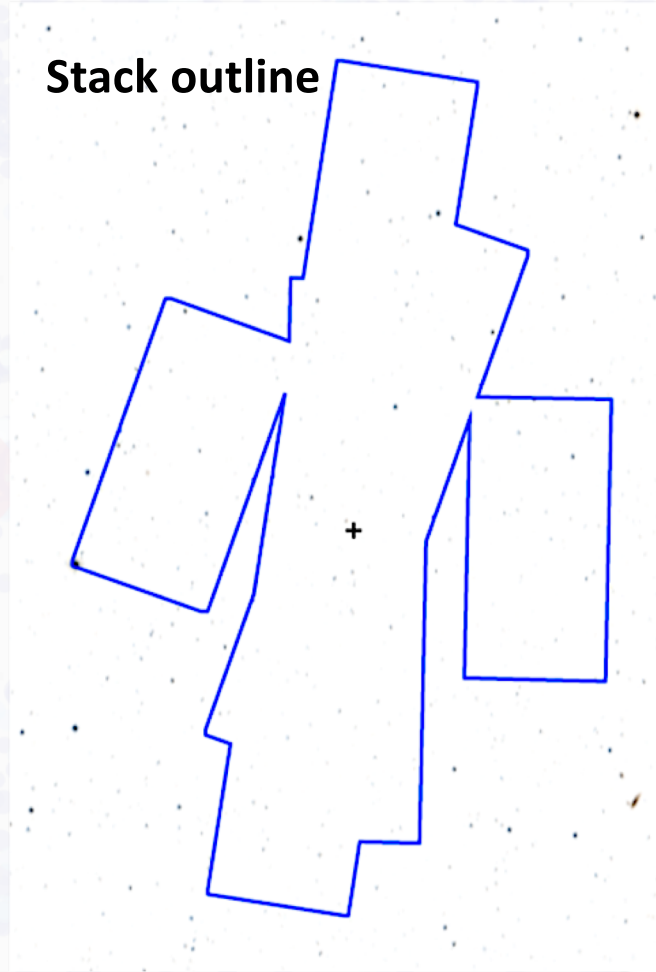

Source detection hierarchy

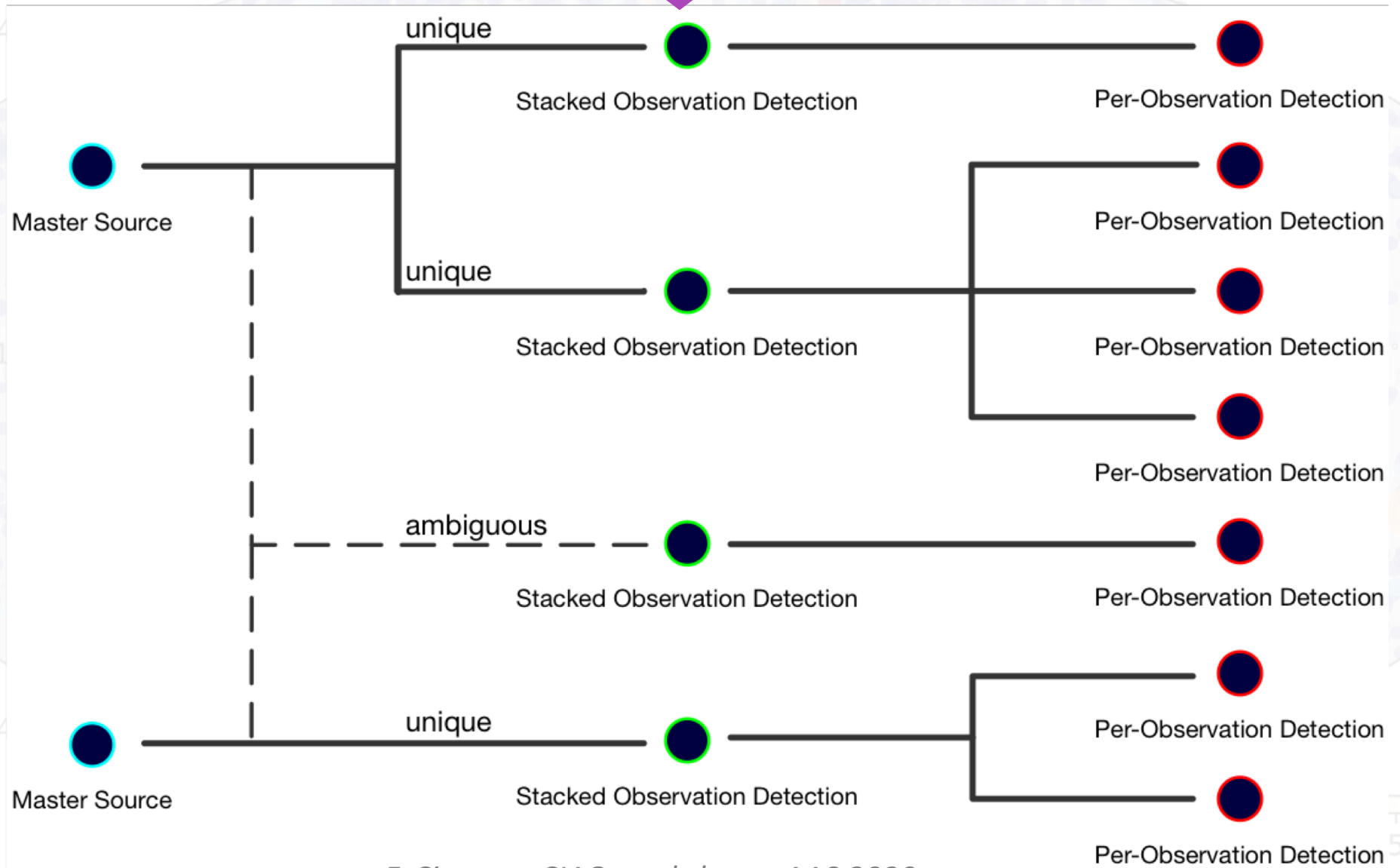

Example: Galactic Center Area

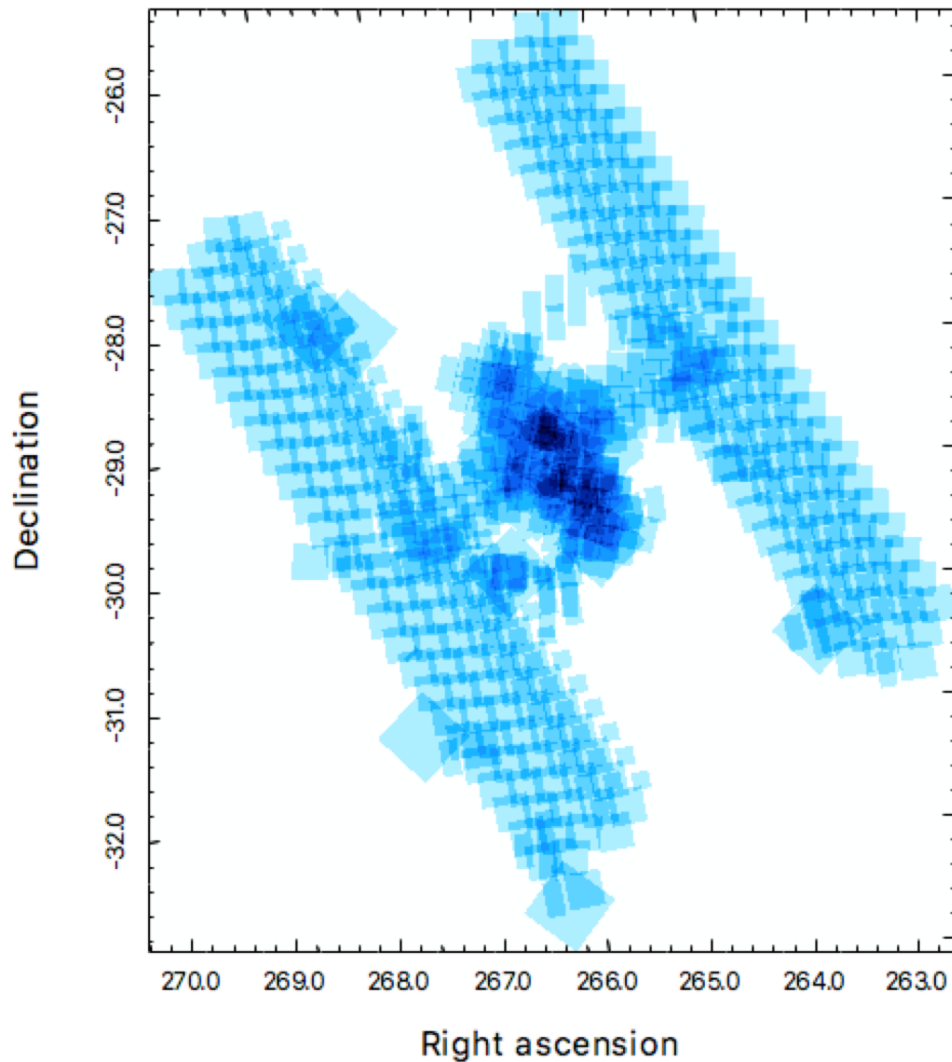

- 534 single *Chandra* observations
- 379 stacks (36 HRC and 343 ACIS)
- Total area covered $\sim 19 \text{ deg}^2$
- Total exposure time $\sim 9 \text{ Ms}$

100 1000
ons per stack

1 2 5 :
Observations p

Example: Galactic Center Area

Sgr A* - central stack of 71 observations

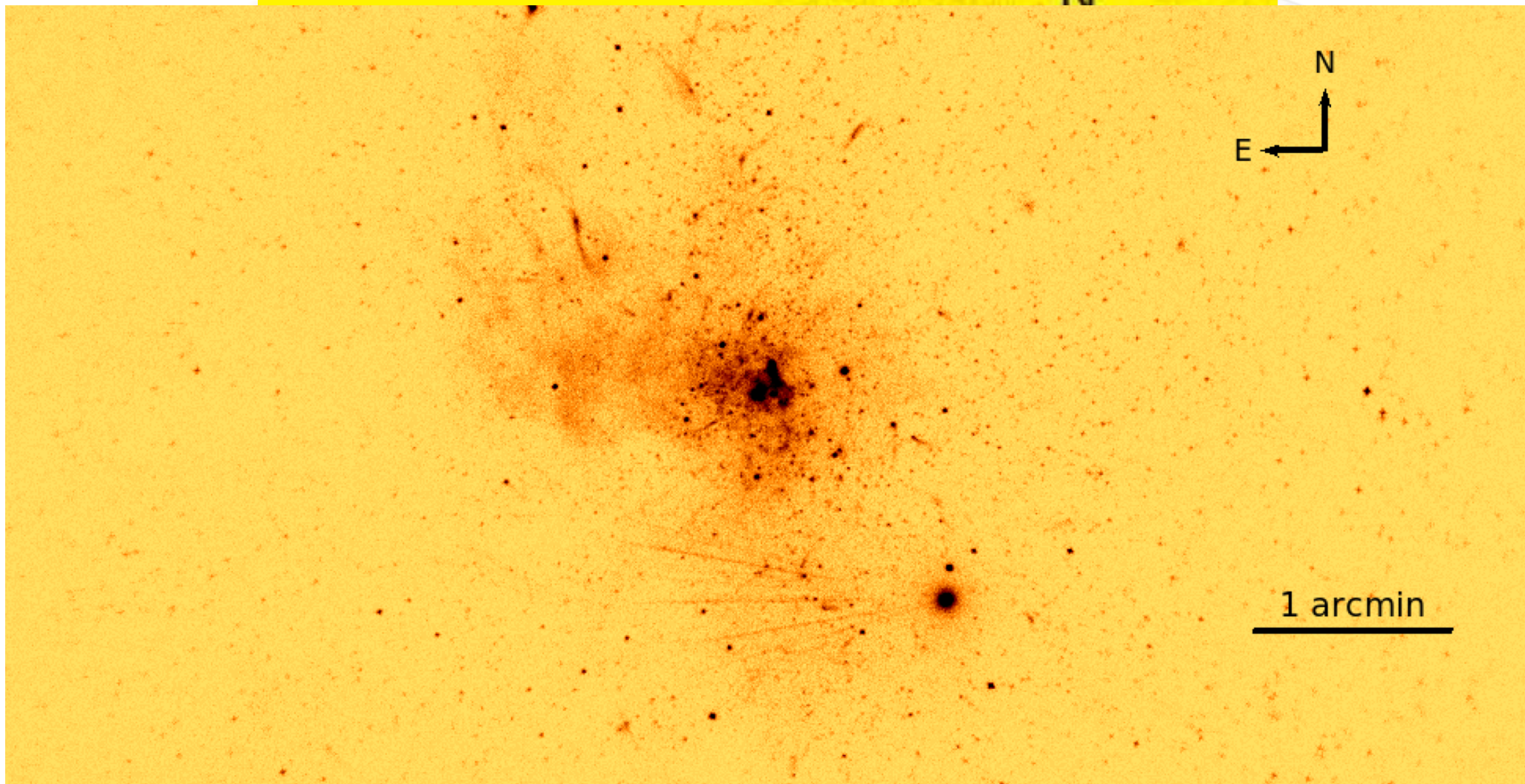

100 1000
ons per stack

1 2 5
Observations p

CSC 2.0 features

CHAND
SOURCE CAT

- Source detection on stacked observations
- **New source detection approach**
 - **Wavelet detection *plus* Voronoi tessellation algorithm**
 - **Maximum likelihood estimator to improve on-axis detection (~5 net counts for exposures < 15 ks)**

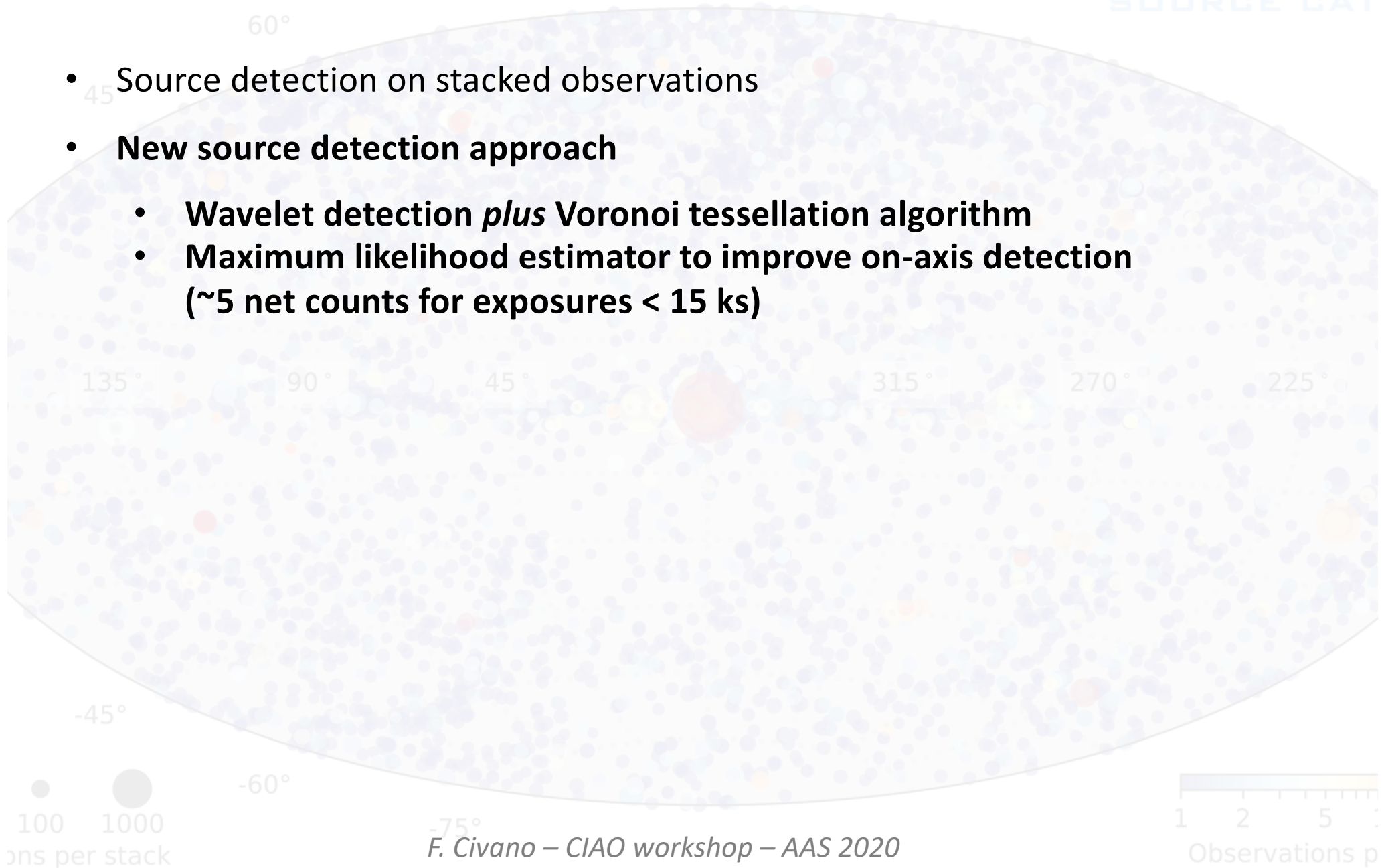

Detection: reaching the faintest sources

Detection in:

- Both release 1 and 2
- Release 2 new
- × Release 1 false

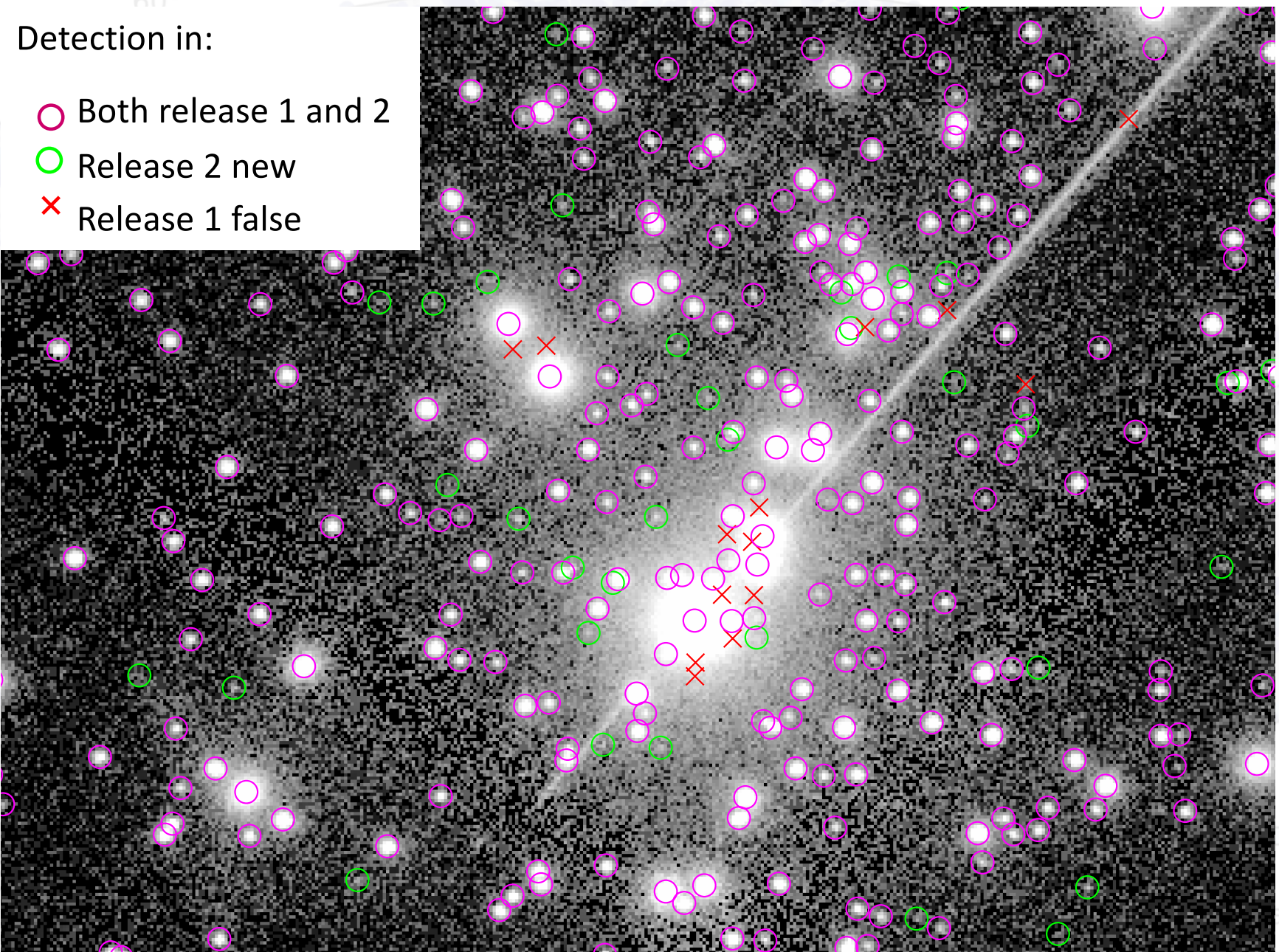

100 10
ons per st

5
tions p

Master matching process

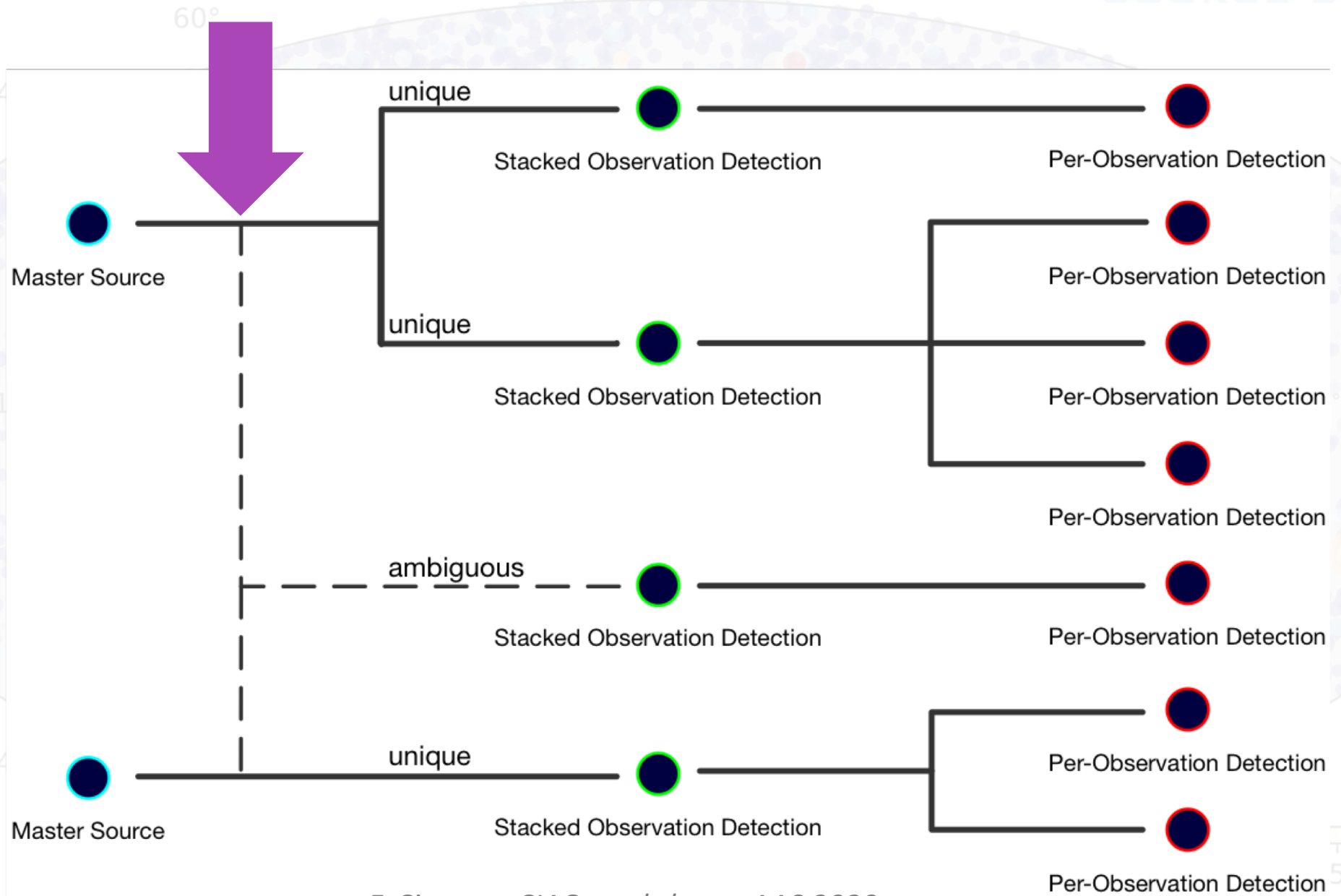

Detections and sources

CHANDRA
SOURCE CAT

On-axis: *Chandra* PSF is small ($\sim 1''$)

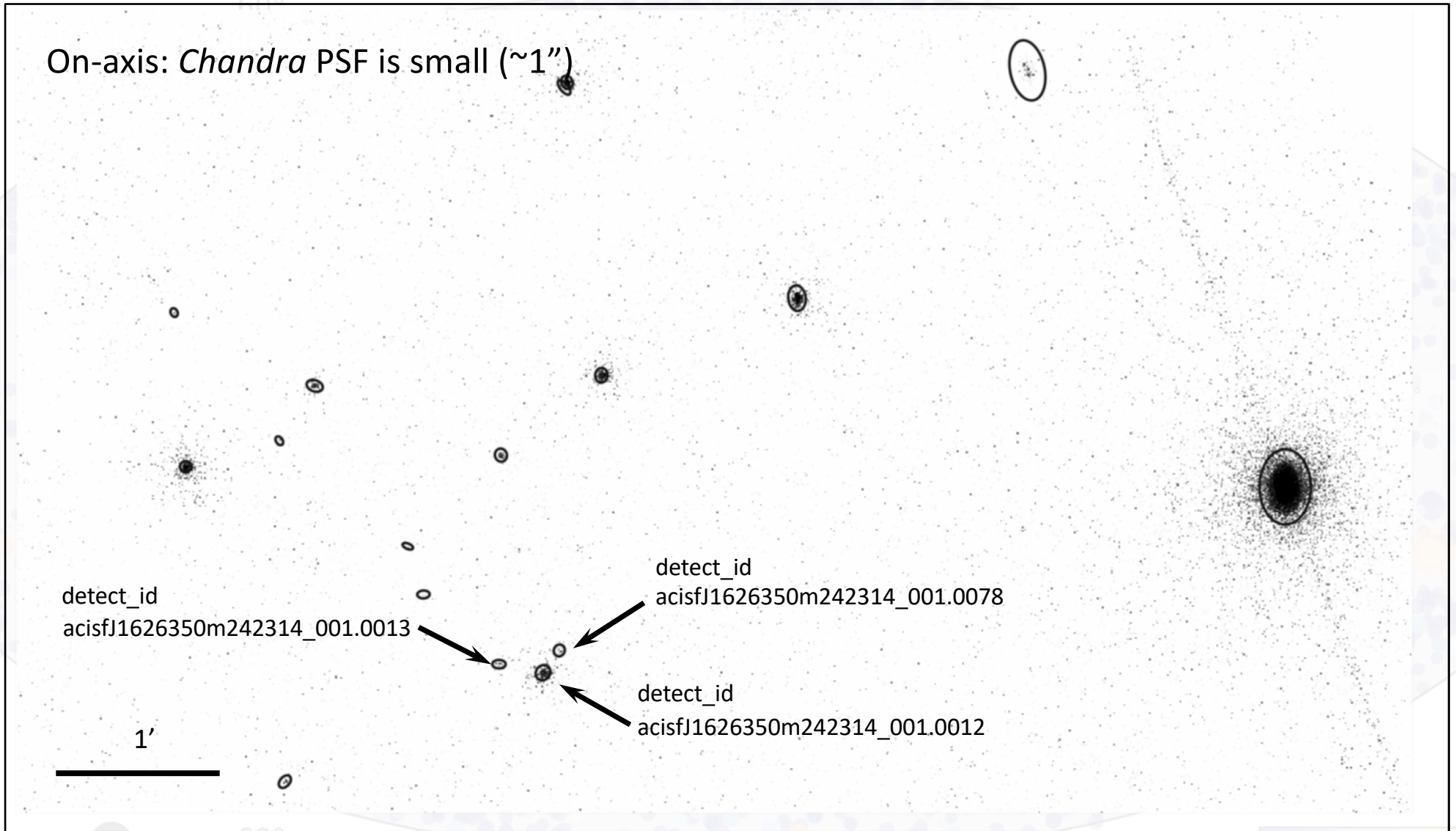

100 1000
ons per stack

-75°
F. Civano – CIAO workshop – AAS 2020

1 2 5 :
Observations p

Detections and sources

Off-axis: *Chandra* PSF is much larger

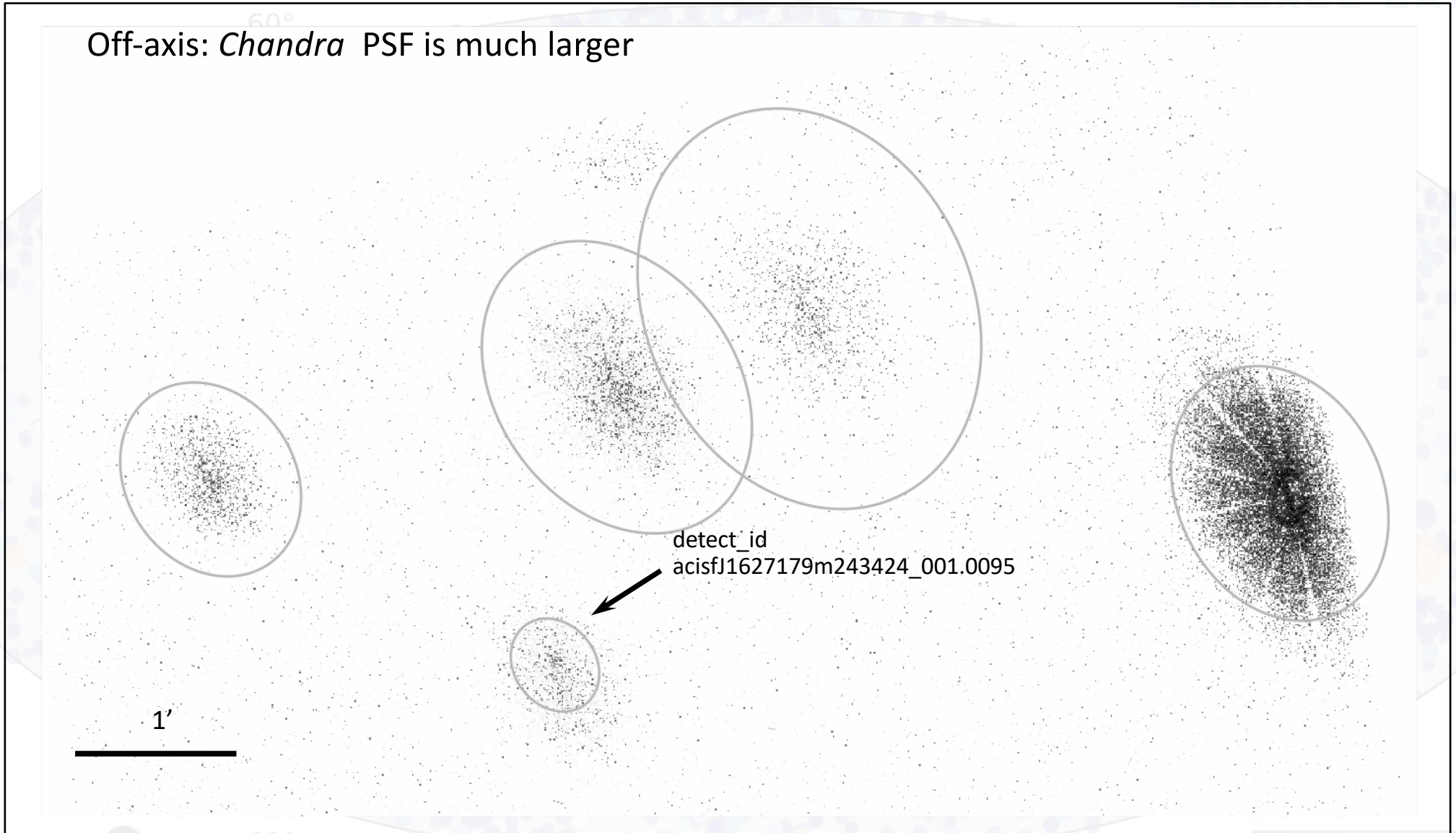

Detections and sources

Multiple sources on-axis may be **CONFUSED** in off-axis observations of the same field

The catalog reconciles detections at different off-axis angles

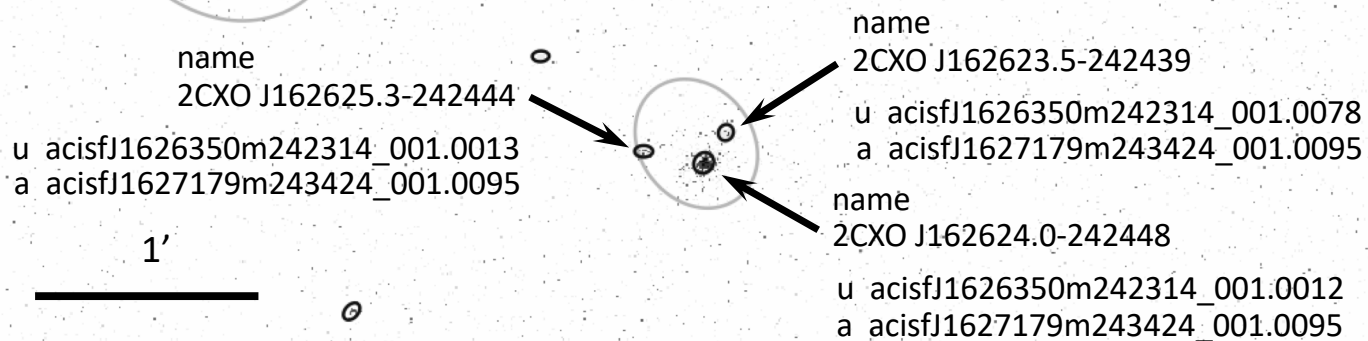

-60°

100 1000
ons per stack

-75°

F. Civano – CIAO workshop – AAS 2020

1 2 5 :
Observations p

Master sources and detections

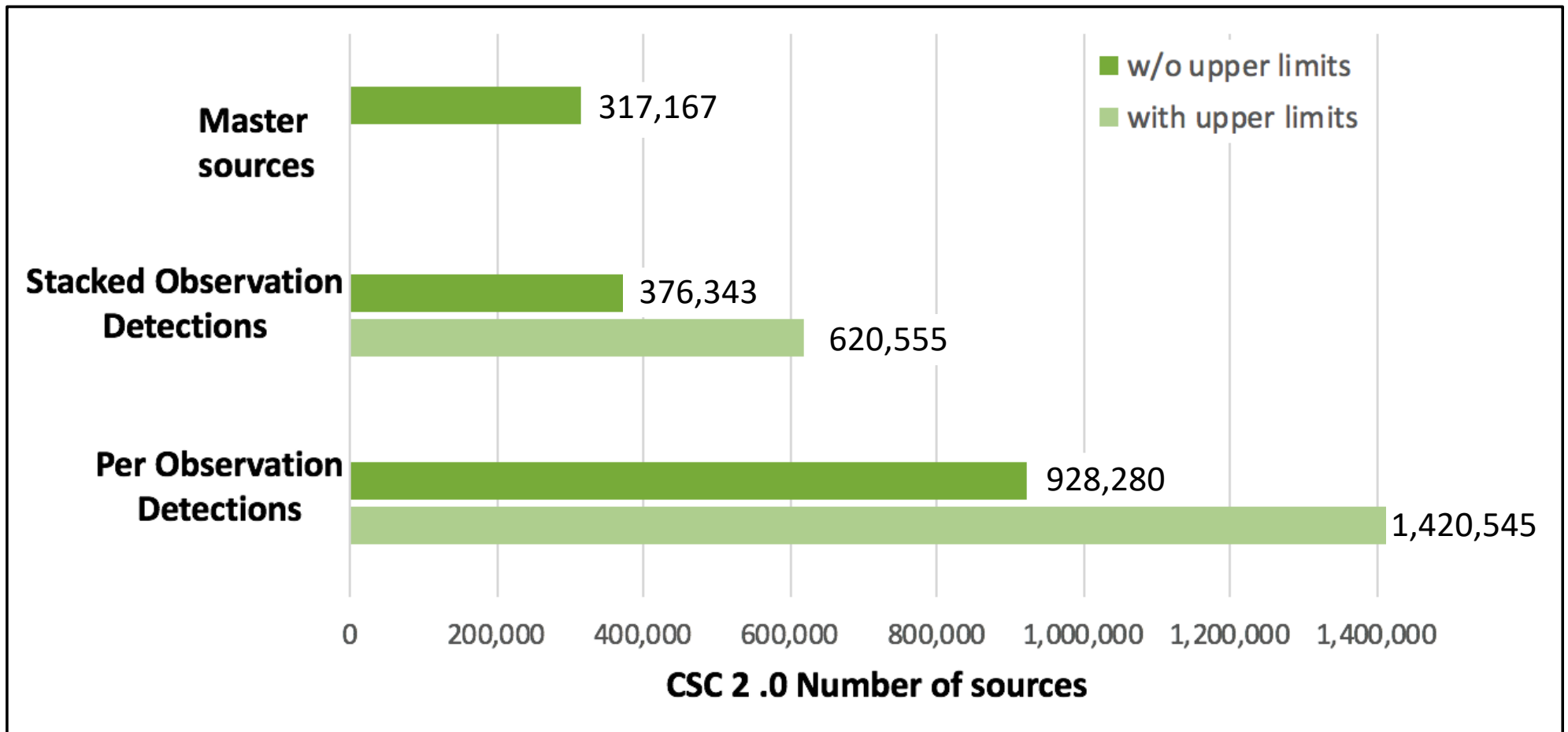

100 1000
ons per stack

-60°

-75°

F. Civano – CIAO workshop – AAS 2020

1 2 5 :
Observations p

CSC 2.0 features



- Source detection on stacked observations
- New source detection approach
 - Wavelet detection *plus* Voronoi tessellation algorithm
 - Maximum likelihood estimator to improve on-axis detection (~5 net counts for exposures < 15 ks)
- **MCMC draws provide relative astrometry position error *ellipses***
- Aperture photometry PDFs computed using Bayesian algorithms
- Multiple observations grouped by multi-band Bayesian Blocks algorithm to improve S/N even for variable sources (properties archived for each block)
- Integrated multi-band limiting sensitivity computed on 4" x 4" pixels

100 1000
ons per stack

-75°
F. Civano – CIAO workshop – AAS 2020

1 2 5 :
Observations p

CSC 2.0 features

CHAND
SOURCE CAT

- Source detection on stacked observations
- New source detection approach
 - Wavelet detection *plus* Voronoi tessellation algorithm
 - Maximum likelihood estimator to improve on-axis detection (~5 net counts for exposures < 15 ks)
- MCMC draws provide relative astrometry position error *ellipses*
- **Aperture photometry; multi-band Bayesian Blocks algorithm**

100 1000
ons per stack

-75°
F. Civano – CIAO workshop – AAS 2020

1 2 5 :
Observations p

Source Properties: Aperture Photometry

Fluxes are measured in each observation: Bayesian approach for simultaneous aperture photometry estimation in crowded fields (*Primini, F. A. & Kashyap, V. L. 2014*)

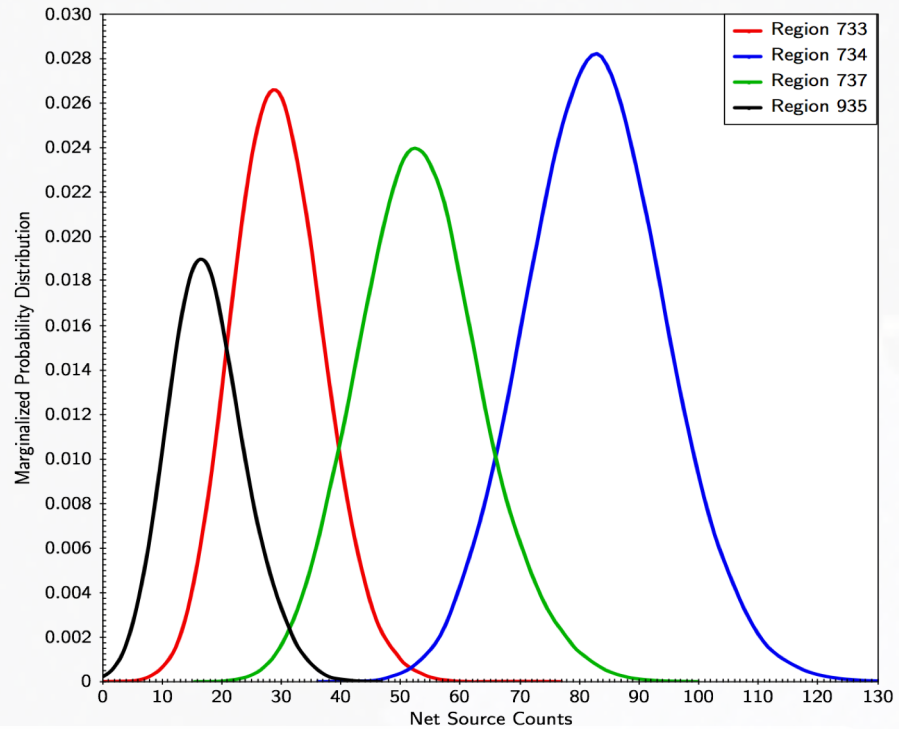
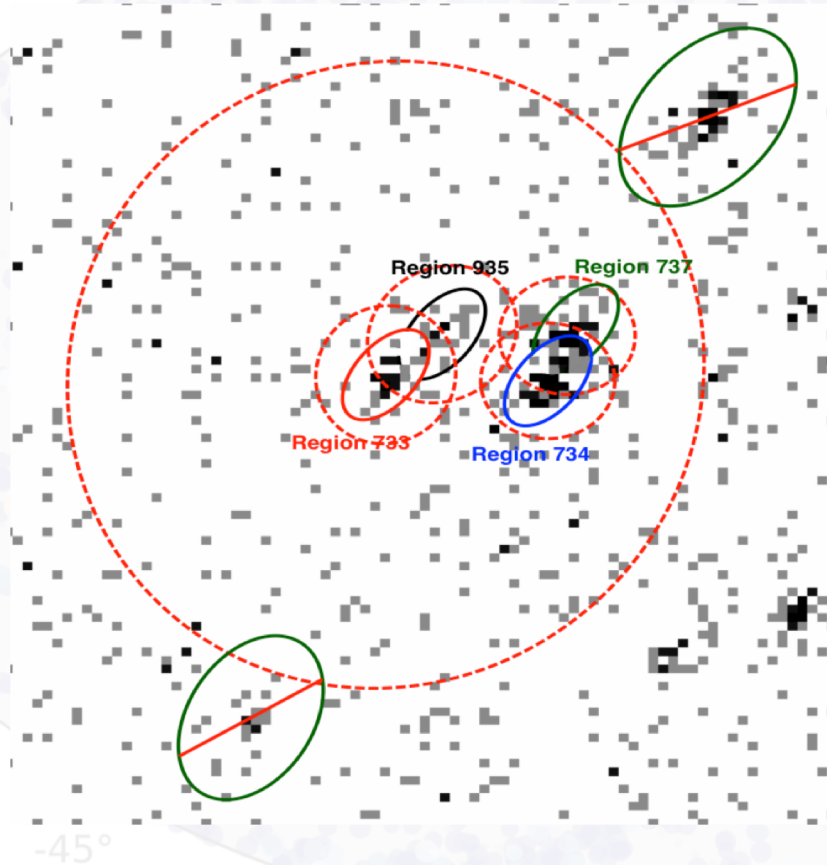

Photometric PDFs are estimated simultaneously for the overlapping detections

100 1000
ons per stack

1 2 5 :
Observations p

Source Properties: Aperture Photometry

Bayesian Model

Analyze sources with overlapping apertures, near-by sources, and background simultaneously.

Joint posterior for source fluxes and background flux (for single observation):

$$P(s_1 \dots s_n, b | C_1 \dots C_n, B) = K \times P(b) P_{Pois}(B | \phi) \prod P(s_i) P_{Pois}(C_i | \theta_i)$$

$$\theta_i = E_i \times \left[\sum_{j=1}^n f_{ij} s_j + \Omega_i b \right]; \quad \phi = E_b \times \left[\sum_{i=1}^n g_i s_i + \Omega_b b \right]$$

Counts in overlapping regions assigned to brightest source

Master source flux for source s_k in an n -source bundle is determined from the Bayesian block for that source with the largest exposure. In this case:

$$P(s_k | \{C_i^j\}, \{B^j\}) \cong P(s_k) \prod_{j=1}^m \left[P_{Pois}(B^j | \hat{\phi}^j) \times P_{Pois}(C_k^j | \hat{\theta}_k^j) \prod_{i=1, i \neq k}^n P_{Pois}(C_i^j | \hat{\theta}_i^j) \right]$$

In all cases, a marginalized posterior is obtained for each source are obtained by integration over all other sources and background.

Posteriors optimized and sampled using MCMC in Sherpa.

Grouping Observations to Improve S/N

- Multi-band Bayesian Blocks analysis (*Scargle+2013*) on detection fluxes to identify observations that can be analyzed/grouped together
- The combined properties for the longest exposure Bayesian Block are databased, but the properties for *all* blocks are recorded in a FITS data product

2CXO J1219389+291724 — single flux-ordered block

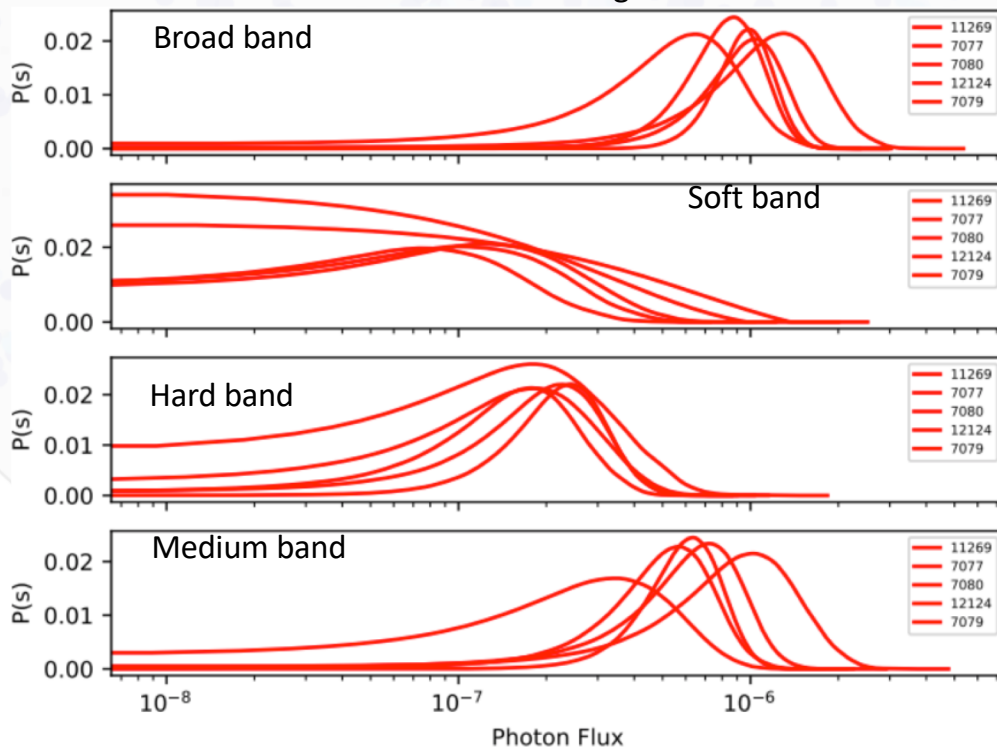

2CXO J1219505+293323 — multiple flux-ordered blocks

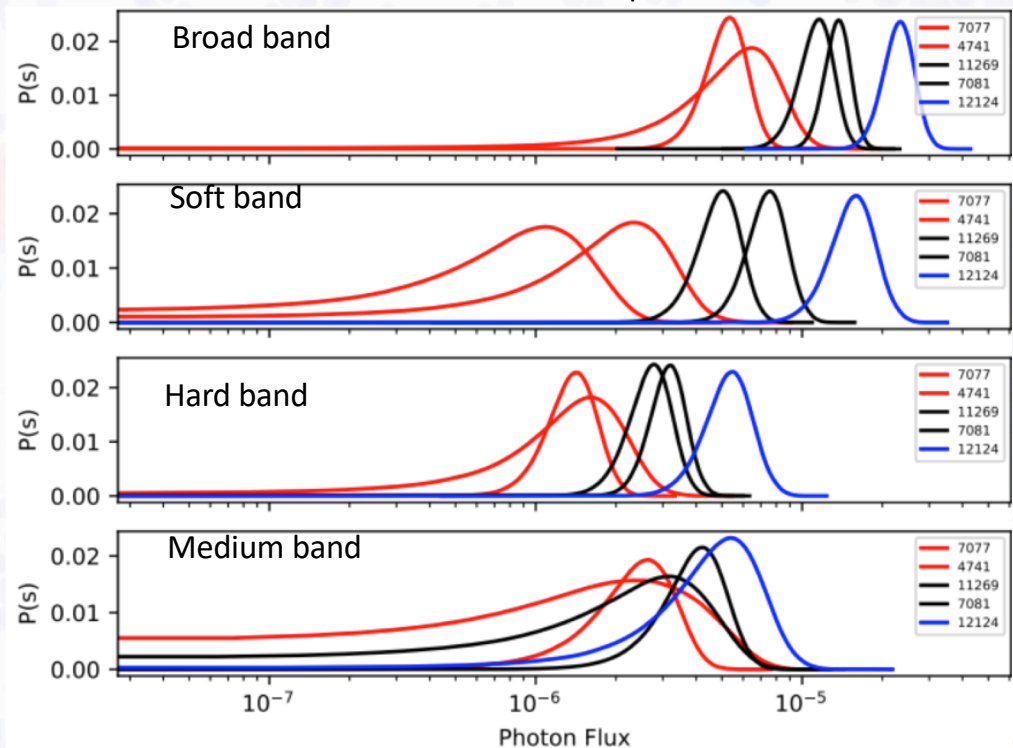

Grouping Observations to Improve S/N

- Multi-band Bayesian Blocks analysis (*Scargle+2013*) on detection fluxes to identify observations that can be analyzed/grouped together

• The combined properties for the longest exposure Bayesian Block are databased, but master level fluxes --> the best flux block determined in the Bayesian Blocks analysis

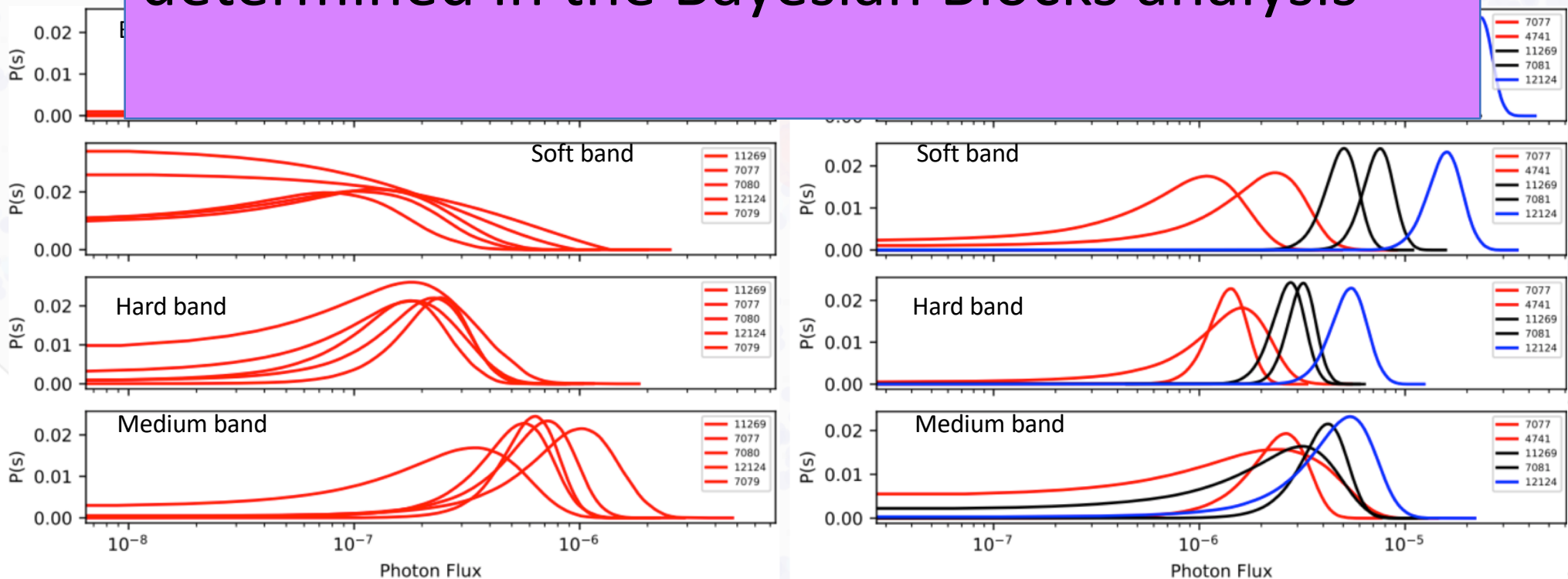

Temporal Variability

- **Single observation:** Gregory-Loredo Test: Hypothesis rejection test (i.e., odds ratio of assuming variability vs not assuming it). The probability that events detected are not arriving at a uniform rate. Used to estimate intra-obs variability (pick max prob among stack obsids).
- **Multiple observations:** Inter-observation variability. Variability test is based on a likelihood ratio between the null hypothesis of no variability, and the assumption of variability, when several observations are considered.

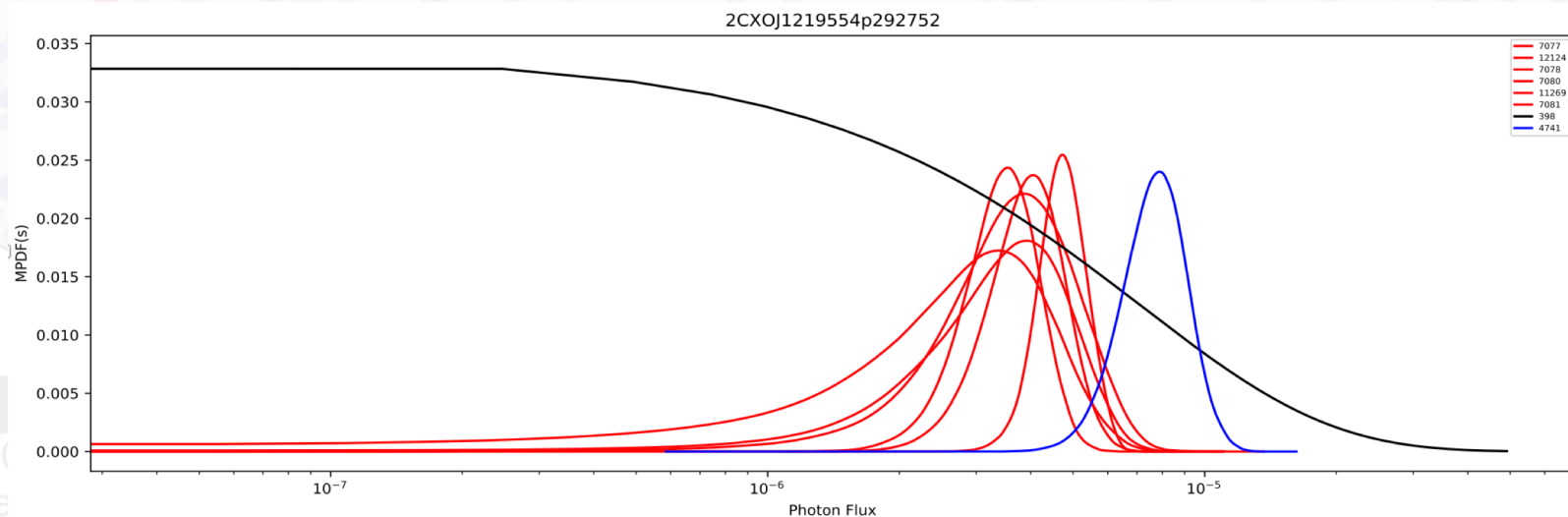

CSC 2.0 features

CHAND
SOURCE CAT

- Source detection on stacked observations
- New source detection approach
 - Wavelet detection *plus* Voronoi tessellation algorithm
 - Maximum likelihood estimator to improve on-axis detection (~5 net counts for exposures < 15 ks)
- MCMC draws provide relative astrometry position error *ellipses*
- Aperture photometry; multi-band Bayesian Blocks algorithm
- **Multi-band limiting sensitivity computed on 4" x 4" pixels**

100 1000
ons per stack

-75°
F. Civano – CIAO workshop – AAS 2020

1 2 5 :
Observations p

CSC 2.0 new features

CHAND
SOURCE CAT

- Source detection on stacked observations
- New source detection approach
 - Wavelet detection *plus* Voronoi tessellation algorithm
 - Maximum likelihood estimator to improve on-axis detection (~5 net counts for exposures < 15 ks)
- MCMC draws provide relative astrometry position error *ellipses*
- Aperture photometry; multi-band Bayesian Blocks algorithm
- Multi-band limiting sensitivity computed on 4" x 4" pixels
- **Spectra extraction of ALL DETECTIONS and spectral analysis**

100 1000
ons per stack

-75°
F. Civano – CIAO workshop – AAS 2020

1 2 5 :
Observations p

Spectral Analysis

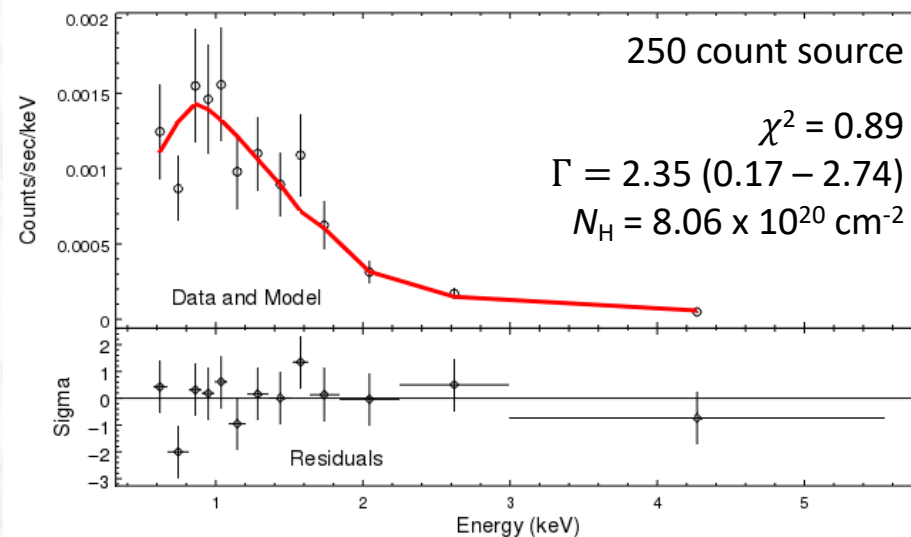
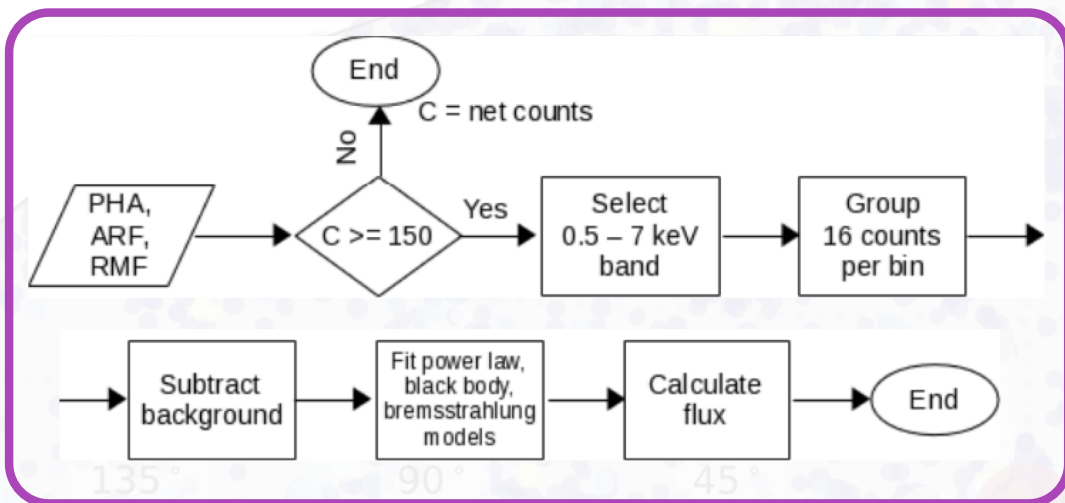

Abs. power law

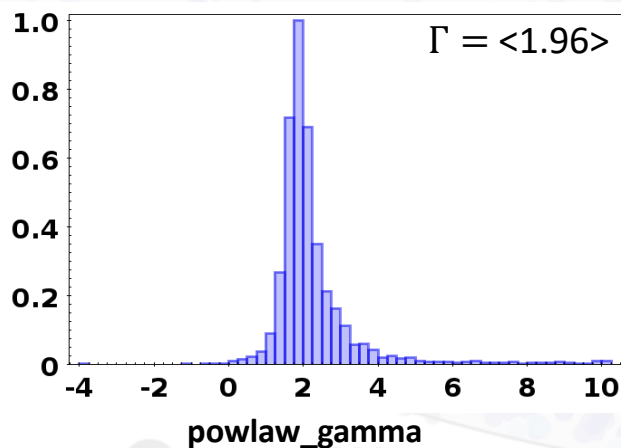

Abs. black body

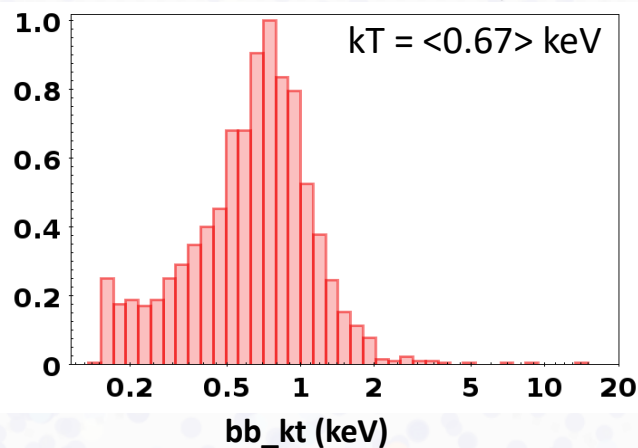

Abs. bremsstrahlung

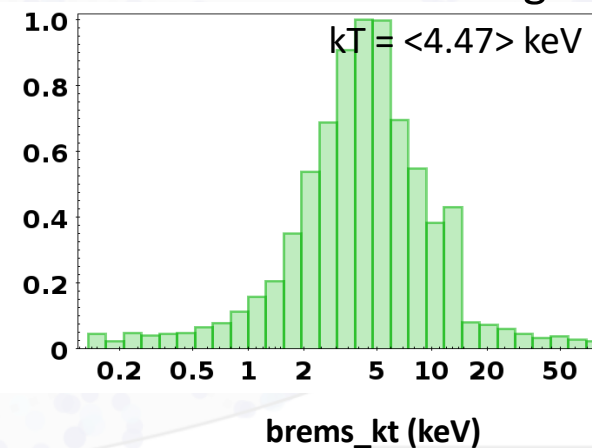

Joint Spectral Fits

- Sources that are observed multiple times are grouped by the Bayesian blocks analysis
- All spectra in the block are simultaneously fit

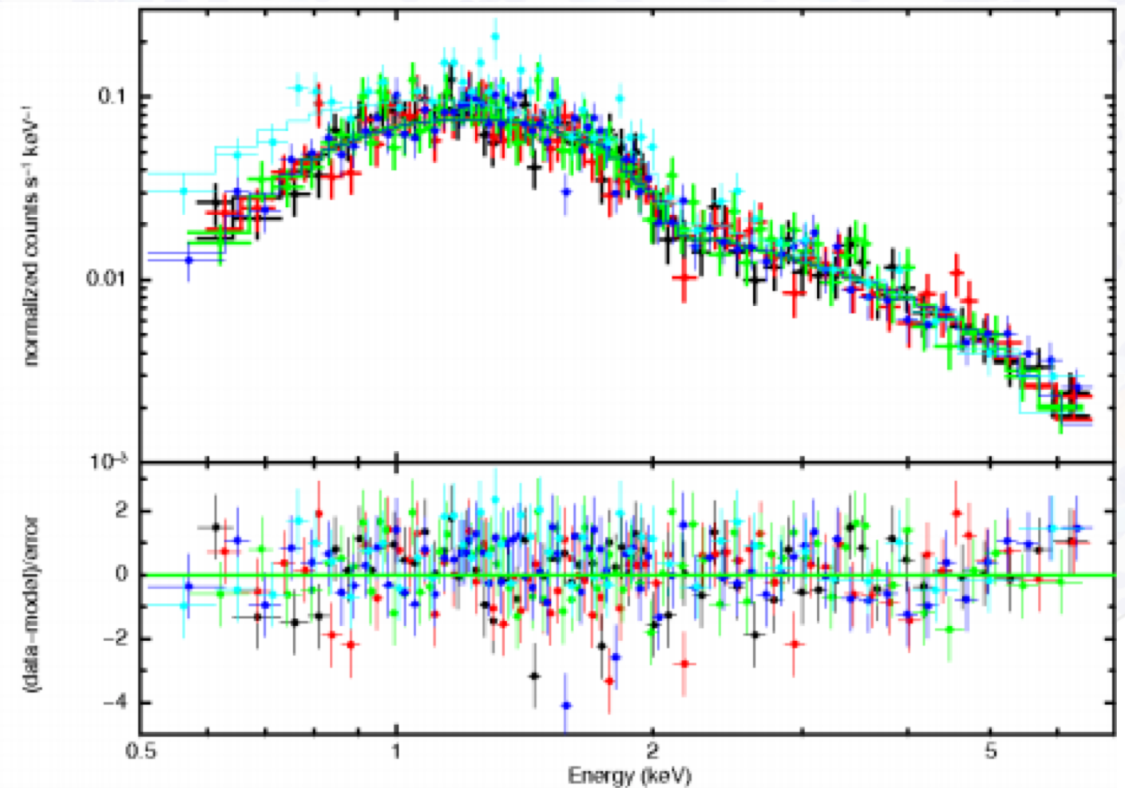
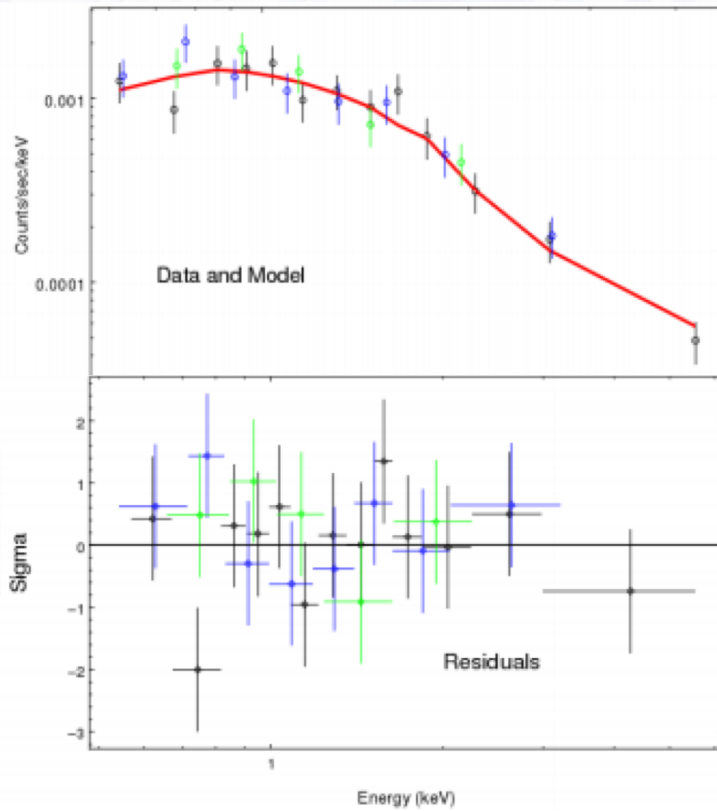

CSC 2.0 features

CHAND
SOURCE CAT

- Source detection on stacked observations
- New source detection approach
 - Wavelet detection *plus* Voronoi tessellation algorithm
 - Maximum likelihood estimator to improve on-axis detection (~5 net counts for exposures < 15 ks)
- MCMC draws provide relative astrometry position error *ellipses*
- Aperture photometry; multi-band Bayesian Blocks algorithm
- Multi-band limiting sensitivity computed on 4" x 4" pixels
- Spectra extraction and spectral analysis
- **Extended emission properties**

100 1000
ons per stack

-75°
F. Civano – CIAO workshop – AAS 2020

1 2 5 :
Observations p

Extended sources (>30")

Tycho's SNR
888 ks; 58 million X-ray photons

- 1,299 highly extended sources
- SNRs, cluster of galaxies, extended galaxies, jets, etc.
- Photometric properties are integrated over a convex hull bounding region
- Fluxes and regions are provided

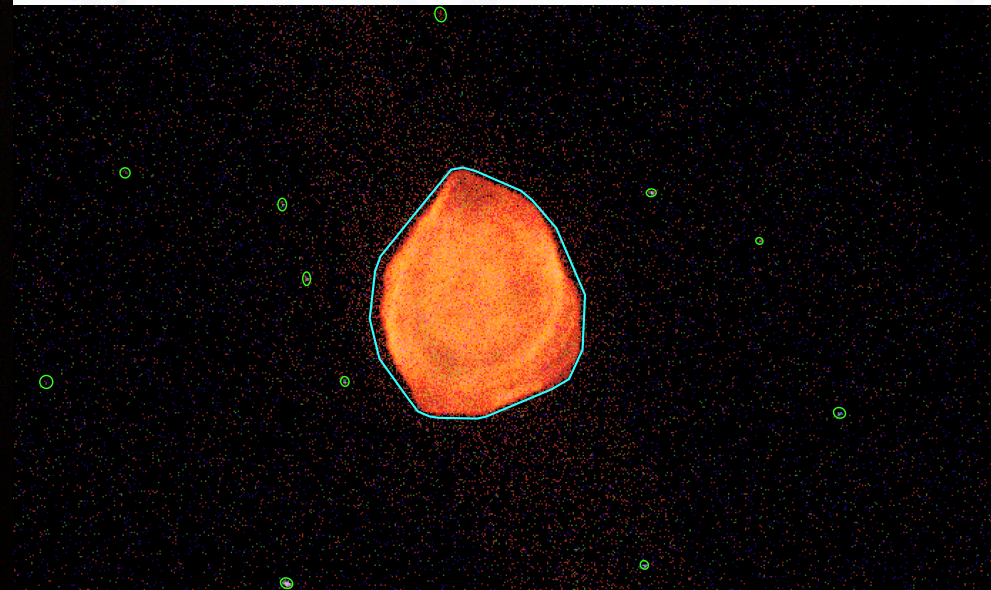
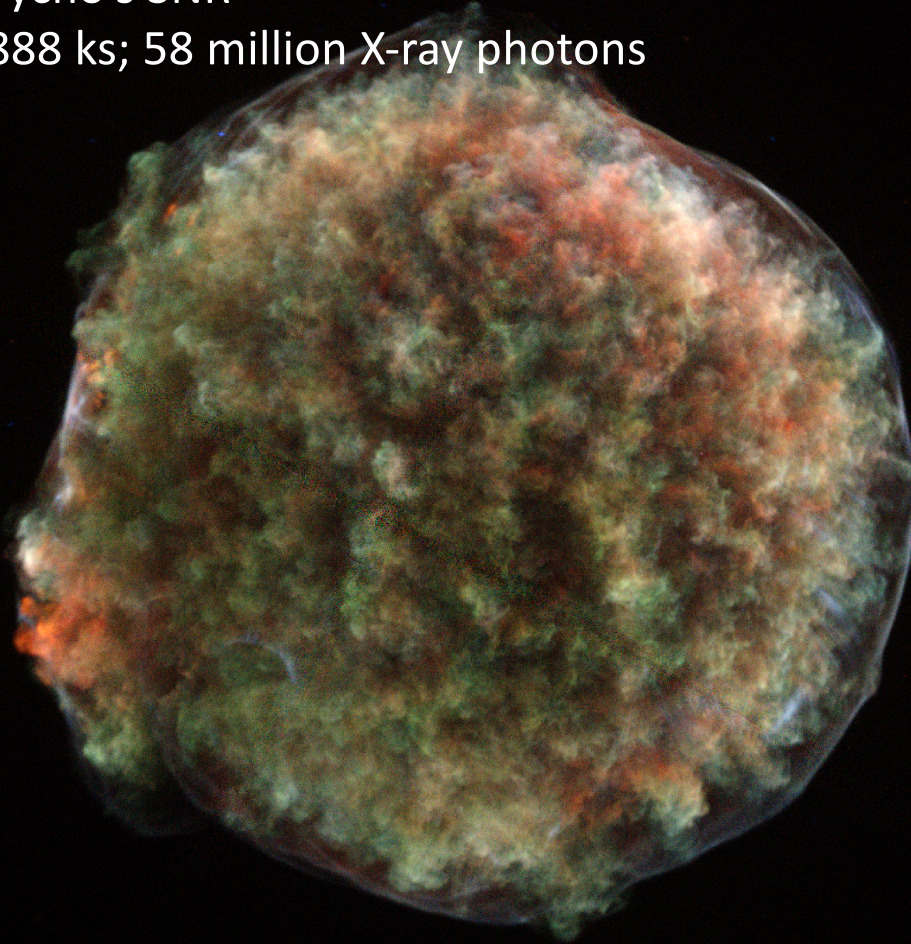

100 1000
ons per stack

-60°

-75°

F. Civano – CIAO workshop – AAS 2020

1 2 5
Observations p

Databased properties

CHAND
SOURCE CAT

Master Source Properties

- Source name, position and position errors, significance, source flags, multi-band deconvolved extent, multi-band aperture photometry (photon and energy fluxes, spectral model fluxes [multiple spectral models]), hardness ratios, spectral model fits [multiple spectral models], multi-band intra- and inter-observation temporal variability

Stacked-Observation Detection Properties

- Position and position errors, multi-band significance, detection flags and codes, multi-band deconvolved extent, multi-band aperture photometry (net counts and count rates, photon and energy fluxes), aperture parameters, hardness ratios, multi-band intra- and inter-observation temporal variability

Per-Observation Detection Properties

- Detector position, multi-band significance, detection flags and codes, multi-band raw, PSF, and deconvolved extent, multi-band aperture photometry (total counts, net counts and count rates, photon and energy fluxes, spectral model fluxes [multiple spectral models]), masked aperture parameters, spectral model fits [multiple spectral models], multi-band intra-observation temporal variability

100 1000
ons per stack

-75°
F. Civano – CIAO workshop – AAS 2020

1 2 5 :
Observations p

Science-Ready FITS Data Products

~25 million files, ~32 TB

Observation Data Products

- Observation event list, aspect solution and histogram, bad pixel map, FoV, pixel mask
- Multi-band images, background images, exposure maps

Stacked-Observation Data Products

- Stack event list, FoV, merged detection list
- Multi-band images, background images, exposure maps, limiting sensitivity

Detection Region Data Products

- Detection region stack and observation region definitions, event lists
- Multi-band per-stack and per-observation images, exposure maps, position error MCMC draws, aperture photometry PDFs
- Multi-band per-observation PSFs, light curves
- Per-observation PHA spectrum, RMF, ARF

Source Level Data Products

- Aperture photometry PDFs, per-Bayesian block properties (aperture photometry fluxes, model energy fluxes, spectral fits, hardness ratios)

100 1000
ons per stack

-75°
F. Civano – CIAO workshop – AAS 2020

1 2 5 :
Observations p

Catalog Access

<http://cxc.cfa.harvard.edu/csc/>



Browser navigation bar showing address bar with <http://cxc.cfa.harvard.edu/csc/>, search, star, and other icons. Below the address bar are various bookmarks including Google Maps, Bank of America, Belmont Savings, Astro, OPS, webTA, SAO/NASA ADS C..., and Other Bookmarks.

CHANDRA X-RAY OBSERVATORY logo with satellite image. Navigation links: CXC HOME, PROPOSER, ARCHIVE, DATA ANALYSIS, INSTRUMENTS & CALIBRATION, FOR THE PUBLIC. Search bar: Search <http://cxc.harvard.edu/csc2/>. Contact the CXC HelpDesk.

Chandra Source Catalog Release 2.0 (CSC 2.0)

[What's New?](#) | [Watch Out](#)

The Chandra Source Catalog (CSC) is the definitive catalog of X-ray sources detected by the *Chandra X-ray Observatory*. Version 2.0 (CSC2) is the second major release of the catalog, and represents a significant improvement with respect to version 1.1 in terms of sky coverage, sensitivity and capabilities. CSC2 includes measured properties for **317,167 unique compact and extended X-ray sources** in the sky, allowing statistical analysis of large samples, as well as individual source studies. Extracted properties are provided for **928,280 individual observation detections** identified in 10,382 *Chandra* ACIS and HRC-I imaging observations released publicly through the end of 2014. CSC 2.0 also includes—as an "alpha" release—photometric properties for 1,299 highly extended ($\approx 30''$) sources, together with **surface brightness polygons** for several contour levels. There are **approximately 1,700 columns** of tabular data with pertinent information about each source across 5 bands (broad, hard, medium, soft, and ultra-soft) for ACIS and 1 band (wide) for HRC (see the [energy-bands page](#) for the definition of these bands), and 40 [data products](#) per source. The total size of the archive is close to 36 TB.

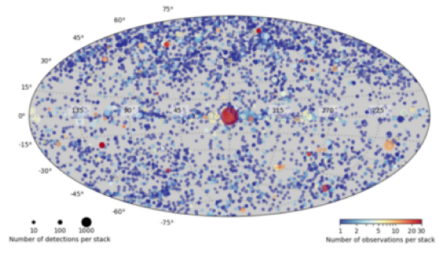

The locations, in Galactic coordinates, of the CSC 2.0 detections. The size of each symbol is proportional to the logarithm of the number of sources detected in the [stack](#), while the color encodes the number of closely-located observations.

CSC Data Access

- [CSCview](#) (help)
- [Quick Search](#) NEW
- [View in WWT](#)
- [CIAO scripts](#)
- [Virtual Observatory](#)

CSC Homepage

- [About the Catalog](#)
 - [Overview](#)
 - [Catalog Organization](#)
 - [Catalog Release Views and Database Access Views](#)
 - [Catalog Statistical Characterization](#)
 - [Caveats and Limitations](#)
 - [Version History](#)
- [Creating the Catalog](#)
 - [Observation Selection](#)
 - [Catalog Processing](#)
 - [Data Products](#)
 - [Chandra Data Archive](#)
- [Using the Catalog](#)
 - [Threads](#)
 - [CSCview GUI](#)
 - [CSC CLI](#)
 - [Data Access](#)
- [Catalog Columns](#)
 - Master Sources Table: [alphabetical](#) | [by context](#)
 - Stacked Observation Detections Table: [alphabetical](#) | [by context](#)
 - Per-Observation Detections Table: [alphabetical](#) | [by context](#)
- [Column Descriptions](#)
 - [Position and Position Errors](#)
 - [Source Flags](#)
 - [Source Extent and Errors](#)
 - [Energy Bands](#)
 - [Source Fluxes](#)
 - [Source Significance](#)

Navigation buttons for CSC 2.0:

- What is CSC 2.0?
- Explore CSC 2.0 using the World Wide Telescope
- How do I access or download CSC 2.0?
- Are there any caveats for CSC 2.0?
- What properties are available in CSC 2.0?
- Is my favorite source in CSC 2.0?
- How do I find the flux of a source?
- How do I cite CSC 2.0?

100 1000
ns per stack

-75°
F. Civano – CIAO workshop – AAS 2020

1 2 5
Observations p

Data Access

<http://cxc.cfa.harvard.edu/csc/>

CHAND
SOURCE CAT

- The CSCview application
- Quick Search: the CSC web interface **NEW**
- View in the World Wide Telescope
- CIAO scripts
 - search_csc
 - obsid_search_csc
- Using Virtual-Observatory interfaces
 - Astronomical Data Query Language
 - Cone search
 - Table Access Protocol
 - Simple Image Access Protocol

100 1000
ons per stack

-75°
F. Civano – CIAO workshop – AAS 2020

1 2 5 :
Observations p

For a quick view: WWT

CHANDRA SOURCE CATALOG 2.0

Sources: 315880 (100.0%)

Select nearest source

Enter Name or Position:

Optical (DSS)

Show Popular Places

Hide Stack Outlines

Hide CSC 2.0 Sources

Load XMM Sources

Show Milky Way outline

Full screen Hide banners

Help Credits

Source: 2CXO J055033.8-682416

Copy source name to clipboard Search nearby: [NED](#) or [SIMBAD](#) [Zoom to source](#)

α : 5^h 50^m 33.83^s δ : -68° 24' 16.8" (ICRS)

<i>95% confidence position error ellipse</i>	1.29" by 0.56" at 129°
<i>Galactic n_H column density</i>	$6.59 \times 10^{20} \text{ cm}^{-2}$
<i>Aperture-corrected flux (broad band)</i>	$7.964\text{e-}16 \text{ erg cm}^{-2} \text{ s}^{-1}$
<i>Lower confidence limit</i>	2.172e-16
<i>Upper confidence limit</i>	1.376e-15
<i>Source significance (S/N)</i>	2.61
<i>Hard/Medium band hardness ratio</i>	0.075
<i>Lower confidence limit</i>	-0.3467
<i>Upper confidence limit</i>	0.4329
<i>Medium/Soft band hardness ratio</i>	-0.0412
<i>Lower confidence limit</i>	-0.4029
<i>Upper confidence limit</i>	0.3929
<i>Number of ACIS observations</i>	1
<i>Number of HRC observations</i>	0

Please **review** the current [caveats](#) for source properties in CSC 2.0.

SAMP to DS9 or TOPCAT

Data Retrieval: CSCView

The screenshot displays the CSCView interface with several key components and annotations:

- Standard queries:** A red box highlights the 'Standard Queries' list on the left sidebar.
- Properties to be retrieved:** A red box highlights the 'Result Set' table, which lists columns like 'name', 'ra', 'dec', and various error ellipse parameters.
- Criteria to search on: ADQL queries:** A red box highlights the 'Search Criteria' input field containing the query: `(significance >= 5.0)`.
- List of properties that can be selected:** A red box highlights the 'Source Properties' tree on the left, with 'Position Error: Ellipse' selected.
- Cone search and cross-match:** A red box highlights the 'Position Search' section at the bottom, showing options for 'By Name', 'By Coordinates', and 'Cone' search.

At the bottom of the interface, a table shows the results of the search:

Table	Name	Datatype	Units	Description
Master Sources	err_ellipse_r0	double	arcsec	Major radius of the 95% confidence level position error ellipse
Master Sources	err_ellipse_r1	double	arcsec	Minor radius of the 95% confidence level position error ellipse
Master Sources	err_ellipse_ang	double	deg	Position angle (ref. local true north) of the major axis of the 95% confidence level error ellipse

100 1000
ons per stack

1 2 5 :
Observations p

Data Retrieval: CSCView

Chandra Source Catalog: Current Database

Catalog Query Results Products

Retrieved tabular properties

Select FITS data products here

Select	name	ra	dec	err_ellipse_r0 (arcsec)	err_ellipse_r1 (arcsec)	err_ellipse_ang (deg)	conf_flag	sat_src_flg	significance	flux_aper_b (erg/s/cm ²)	flux_aper_lolim_b (erg/s/cm ²)	flux_aper_hilim_b (erg/s/cm ²)	flux_aper_err (erg/s)
<input type="checkbox"/>	2CXO J210635.1+233051	21 06 35.16	+23 30 51.47	2.15	1.59	105.3	TRUE	FALSE	6.32	4.014e-15	1.302e-15	6.727e-15	0.00
<input type="checkbox"/>	2CXO J210643.6+232757	21 06 43.66	+23 27 57.10	1.68	0.98	90.1	TRUE	FALSE	7.03	1.467e-14	1.199e-14	1.735e-14	9.3
<input type="checkbox"/>	2CXO J210644.4+233859	21 06 44.43	+23 38 59.96	1.09	0.64	101.1	TRUE	FALSE	13.87	4.081e-14	3.711e-14	4.450e-14	2.5
<input type="checkbox"/>	2CXO J210646.2+232749	21 06 46.26	+23 27 49.41	2.54	1.68	102.3	TRUE	FALSE	6.63	1.123e-14	8.880e-15	1.345e-14	7.1
<input type="checkbox"/>	2CXO J210646.3+233207	21 06 46.31	+23 32 07.25	1.11	0.84	121.4	FALSE	FALSE	7.33	0.101e-14	8.194e-15	1.212e-14	6.8
<input type="checkbox"/>	2CXO J210647.6+232651	21 06 47.64	+23 26 51.01	2.04	1.37	89.2	TRUE	FALSE	5.93	1.564e-14	1.141e-14	1.965e-14	1.2
<input type="checkbox"/>	2CXO J210649.1+233336	21 06 49.15	+23 33 36.02	0.76	0.41	103.1	TRUE	FALSE	16.07	4.965e-14	4.636e-14	5.295e-14	3.4
<input checked="" type="checkbox"/>	2CXO J210651.7+234321	21 06 51.71	+23 43 21.07	1.59	1.15	156.4	FALSE	FALSE	11.72	6.632e-14	5.926e-14	7.337e-14	4.7
<input type="checkbox"/>	2CXO J210652.8+232718	21 06 52.81	+23 27 18.55	1.09	0.88	105.4	TRUE	FALSE	8.31	1.442e-14	1.195e-14	1.675e-14	8.7
<input type="checkbox"/>	2CXO J210653.3+233327	21 06 53.38	+23 33 27.73	0.77	0.46	106.6	TRUE	FALSE	10.25	2.419e-14	2.174e-14	2.665e-14	2.1
<input type="checkbox"/>	2CXO J210654.4+232657	21 06 54.49	+23 26 57.30	1.51	0.87	92.5	TRUE	FALSE	6.81	1.443e-14	1.209e-14	1.663e-14	1.2
<input type="checkbox"/>	2CXO J210654.5+233242	21 06 54.53	+23 32 42.85	0.62	0.51	140.9	TRUE	FALSE	9.34	2.678e-14	2.373e-14	2.965e-14	2.5
<input type="checkbox"/>	2CXO J210656.1+233221	21 06 56.12	+23 32 21.13	0.50	0.50	0.0	TRUE	FALSE	7.67	1.036e-14	8.883e-15	1.175e-14	7.3
<input checked="" type="checkbox"/>	2CXO J210657.0+233407	21 06 57.05	+23 34 07.20	0.44	0.34	131.5	FALSE	FALSE	16.46	4.774e-14	4.469e-14	5.061e-14	3.3
<input type="checkbox"/>	2CXO J210658.0+233110	21 06 58.09	+23 31 10.56	0.82	0.64	125.1	FALSE	FALSE	5.50	6.315e-15	5.038e-15	7.522e-15	4.7
<input type="checkbox"/>	2CXO J210659.5+232907	21 06 59.56	+23 29 07.87	0.86	0.52	95.8	FALSE	FALSE	5.20	7.514e-15	5.994e-15	8.949e-15	7.0
<input type="checkbox"/>	2CXO J210700.3+233152	21 07 00.39	+23 31 52.25	0.42	0.35	121.2	TRUE	FALSE	8.84	7.032e-15	6.124e-15	7.940e-15	0.00
<input type="checkbox"/>	2CXO J210701.2+233153	21 07 01.21	+23 31 53.00	0.47	0.41	104.0	TRUE	FALSE	6.87	6.232e-15	5.290e-15	7.175e-15	5.6
<input type="checkbox"/>	2CXO J210703.1+233022	21 07 03.13	+23 30 22.21	0.32	0.29	94.9	TRUE	FALSE	19.77	6.002e-14	5.705e-14	6.299e-14	3.6
<input type="checkbox"/>	2CXO J210703.7+233234	21 07 03.80	+23 32 34.14	0.47	0.38	107.9	FALSE	FALSE	5.79	6.494e-15	5.355e-15	7.634e-15	4.1
<input type="checkbox"/>	2CXO J210703.9+233113	21 07 03.97	+23 31 13.24	0.58	0.42	115.2	TRUE	FALSE	5.53	5.989e-15	4.882e-15	7.096e-15	4.9
<input type="checkbox"/>	2CXO J210705.9+232844	21 07 05.96	+23 28 44.18	0.61	0.54	95.1	FALSE	FALSE	6.84	7.911e-15	6.675e-15	9.147e-15	5.9
<input type="checkbox"/>	2CXO J210707.2+234358	21 07 07.25	+23 43 58.39	3.73	3.11	151.6	TRUE	FALSE	6.05	1.038e-14	5.588e-15	1.517e-14	4.5
<input type="checkbox"/>	2CXO J210709.6+233536	21 07 09.65	+23 35 36.26	0.80	0.61	112.5	TRUE	FALSE	5.14	4.771e-15	3.737e-15	5.806e-15	4.0
<input type="checkbox"/>	2CXO J210710.3+234100	21 07 10.39	+23 41 00.58	1.83	1.27	151.5	TRUE	FALSE	5.24	1.641e-14	1.142e-14	2.117e-14	1.2
<input type="checkbox"/>	2CXO J210713.4+233351	21 07 13.43	+23 33 51.83	0.35	0.32	144.2	TRUE	FALSE	5.82	4.859e-15	3.963e-15	5.754e-15	3.8
<input type="checkbox"/>	2CXO J210714.8+233315	21 07 14.82	+23 31 45.15	0.30	0.30	0.0	TRUE	FALSE	13.48	3.540e-14	3.277e-14	3.803e-14	3.1
<input checked="" type="checkbox"/>	2CXO J210715.1+233315	21 07 15.14	+23 33 15.30	0.31	0.30	113.4	FALSE	FALSE	12.87	1.903e-14	1.751e-14	2.054e-14	1.2
<input type="checkbox"/>	2CXO J210715.8+233355	21 07 15.85	+23 33 55.56	0.35	0.32	166.6	TRUE	FALSE	5.97	7.011e-15	5.798e-15	8.157e-15	6.4
<input type="checkbox"/>	2CXO J210715.9+233058	21 07 15.96	+23 30 58.17	0.31	0.30	60.9	FALSE	FALSE	8.95	8.337e-15	7.352e-15	9.264e-15	4.5
<input type="checkbox"/>	2CXO J210717.1+232803	21 07 17.19	+23 28 03.28	0.50	0.43	36.7	FALSE	FALSE	8.60	1.025e-14	8.925e-15	1.149e-14	6.8
<input type="checkbox"/>	2CXO J210720.5+233047	21 07 20.58	+23 30 47.69	0.32	0.31	57.1	FALSE	FALSE	8.67	1.061e-14	9.416e-15	1.181e-14	7.8
<input type="checkbox"/>	2CXO J210722.1+233131	21 07 22.14	+23 31 31.43	0.34	0.34	161.5	TRUE	FALSE	5.14	5.146e-15	4.105e-15	6.128e-15	4.6
<input type="checkbox"/>	2CXO J210723.7+233216	21 07 23.76	+23 32 16.15	0.32	0.31	20.1	FALSE	FALSE	6.14	2.872e-15	2.342e-15	3.403e-15	1.0
<input type="checkbox"/>	2CXO J210724.5+233301	21 07 24.56	+23 33 01.01	0.34	0.32	34.1	FALSE	FALSE	5.63	6.440e-15	5.265e-15	7.614e-15	5.4
<input type="checkbox"/>	2CXO J210731.3+233529	21 07 31.34	+23 35 29.92	0.76	0.54	9.8	TRUE	FALSE	6.92	8.721e-15	7.210e-15	1.014e-14	7.0
<input type="checkbox"/>	2CXO J210735.0+234217	21 07 35.09	+23 42 17.82	2.35	1.87	167.4	TRUE	FALSE	5.03	1.322e-14	8.528e-15	1.770e-14	1.1
<input type="checkbox"/>	2CXO J210735.6+233502	21 07 35.62	+23 35 02.11	0.70	0.45	10.6	TRUE	FALSE	6.76	5.990e-15	4.721e-15	7.188e-15	3.7
<input type="checkbox"/>	2CXO J210741.5+232924	21 07 41.53	+23 29 24.92	0.84	0.48	43.1	TRUE	FALSE	12.39	2.104e-14	1.902e-14	2.305e-14	1.3
<input type="checkbox"/>	2CXO J210742.0+233238	21 07 42.07	+23 32 38.38	0.63	0.49	31.7	FALSE	FALSE	8.09	1.332e-14	1.026e-14	1.553e-14	9.8
<input type="checkbox"/>	2CXO J210746.7+233128	21 07 46.75	+23 31 28.44	1.20	0.75	41.9	FALSE	FALSE	8.99	1.069e-14	8.859e-15	1.241e-14	6.3

Product Type	Product Specifier	Format	Description
Bayesian Blocks source properties	bayesblks	FITS table	Bayesian Blocks source properties
Per-Master source region aperture photometry PDF	srcaperphot_b	FITS table	Per-Master source region aperture photometry PDF; ACIS broad energy band
Per-Master source region aperture photometry PDF	srcaperphot_w	FITS table	Per-Master source region aperture photometry PDF; HRC wide energy band
Event List	regevt3	FITS table	The source region event file consists of a single FITS format event file for each observation
Point Spread Function	psf_b	FITS image	Per-energy-band local model point spread function image (broad energy; ACIS)
Point Spread Function	psf_w	FITS image	Per-energy-band local model point spread function image (wide energy band)
Exposure Map	repxmnan_b	FITS image	Per-energy-band exposure map images (*cm ² ; ACIS)

SAMP to DS9 or TOPCAT

Chandra X-ray Center | Not Secure | cxc.cfa.harvard.edu

CHANDRA X-RAY OBSERVATORY

Proposer | Archive | Data Analysis | Instruments and Calibration | For The Public

Get Chandra Data | Chandra Source Catalog | HelpDesk | CXC Staff | CXC Opportunities | Announcements | Portal | About Chandra

Chandra Source Catalog Release 2.0

The second major release of the Chandra Source Catalog (CSC 2.0) is now complete and available for queries and downloads. It contains 317,167 unique X-ray sources (315,868 compact and 1,299 highly extended sources) covering 550 square degrees of the galactic and extragalactic sky.

Read the full announcement [here](#).

10/24/19

Call for Applications for the NASA Hubble Fellowship Program (NHFP)

On behalf of the NASA Astrophysics Division, the Space Telescope Science Institute (STScI) announces the call for applications for postdoctoral fellowships under the NASA Hubble Fellowship Program (NHFP) beginning in the fall of 2020.

[Announcement of Opportunity](#)
Read the full announcement [here](#).

9/3/19

20 Years of Chandra Science Symposium

New in the 5th Announcement:
Regular Registration and Abstract Deadline Friday, 6 September 2019. Please NOTE that the abstract submission and registration processes are separate. Please NOTE that the regular registration fee is valid through September 6th.

[Symposium Website](#)
Read the full announcement [here](#).

9/3/19

Chandra Source Catalog 2.0

number of observations per stack

Chandra/CIAO Workshop in Hawaii

3-4 January 2020

20 Years of Chandra Symposium

3-6 December 2019

Chandra 20th Anniversary Events

00:00 | 07:11



